

MOTORCYCLE

K-750

THE K-750 MOTORCYCLE
CATALOGUE OF UNITS
AND PARTS

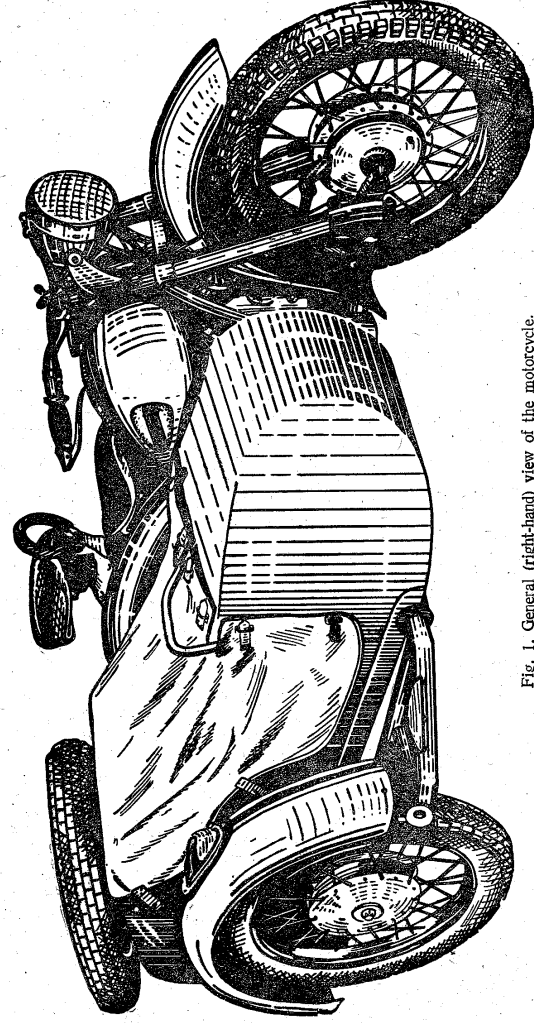

Fig. 1. General (right-hand) view of the motorcycle.

INTRODUCTION

The Illustrated Catalogue of Units and Parts of the K-750 Motorcycle consists of three parts:

Part I — assemblies, units and parts of the Motorcycle;

Part II — fittings manufactured by other works;

Part III — fastenings.

Such a division facilitates the use of the Catalogue as well as ordering spares.

Part I classifies all the assemblies, units and parts of the Motorcycle into groups and subgroups. Fastenings are given under the unit (or part) they fasten.

Part I of the Catalogue gives the description of every part and shows its location in the corresponding unit. This part of the Catalogue is provided with illustrations showing separate units and parts of every group which facilitates ordering spares produced by the motorcycle manufacturing works.

Part II lists assemblies and units delivered to the motorcycle manufacturer by other works. This part shows the main dimensions of wires and tubes, numbers of standards and types of stock used for rubber parts, as well as the thickness of paper washers. Catalogue numbers of bearings and electric equipment parts are given both by the motorcycle manufacturing works and by the contractor works classifications. Drawings with fitting dimensions of the bearings are also given.

This part of the Catalogue assists in ordering

spares and buying parts produced by other manufacturers.

In Part III the fastenings are enumerated in the increasing order of their dimensions. The drawings of the fastenings show their fitting dimensions as well as the number of fastenings per group and for the motorcycle as a whole.

This Part assists in ordering any fastening as well as in replacing or producing it in case of need.

The catalogue number of any motorcycle part (except fastenings) consists of seven or eight figures. The first two figures of a seven-figure number (or the first three of an eight-figure number) show the type of the motorcycle wherefrom the part is taken. E. g., the spacing tube goes under number 7201102, where: 72 — the first two figures — give the type of the motorcycle (here — type M-72); 01 — the next two figures — the number of the group (here — the engine group); 102 — the last three figures — the number of the part in the group (here — the spacing tube).

Another example: the axle for sidecar wheel is placed under number 65020201, where: 650 — the first three figures — give the type of the motorcycle (here — type K-650); 20 — the next two figures — the number of the group (here — the sidecar chassis group); 201 — the last three figures — the number of the part in the group (here — the axle for sidecar wheel).

Some numbers of the parts and units end in a hyphenated letter. E. g.: 7201134-A — the drain

plug. The letter «A» indicates that some alterations were made in the design of the part but it is still interchangeable with old one.

Letter «П» indicates that the part is made of plastic.

Other letter indices show that some alterations were made in the design of a part and, as a result of these alterations it is not interchangeable with the old one, e.g.: 7201152-B — holder for contact breaker cover, with a strip.

Numbers with letters P1, P2 and P3 indicate that the parts have been manufactured for the 1st, 2nd and 3rd repair dimensions.

In the column headed «Notes» the letter «B» indicates that the part of the K-750 motorcycle is interchangeable with that of the M-72 motorcycle.

When ordering spares it is essential to indicate the number and name of the part. It should be noted that the main parts of the crank mechanism are divided into groups within the tolerance limits. Parts belonging to a certain group are identified by a special colour index marked on the part. That's why the mating parts of the crank mechanism, e. g., the piston (the hole in the boss), the piston pin and the connecting rod small end should have the same colour index.

Supplement I shows the colour indices of the parts according to the parts dimensions.

The fastenings of the above-mentioned units are given in the summary tables and are indicated by a six-figure number.

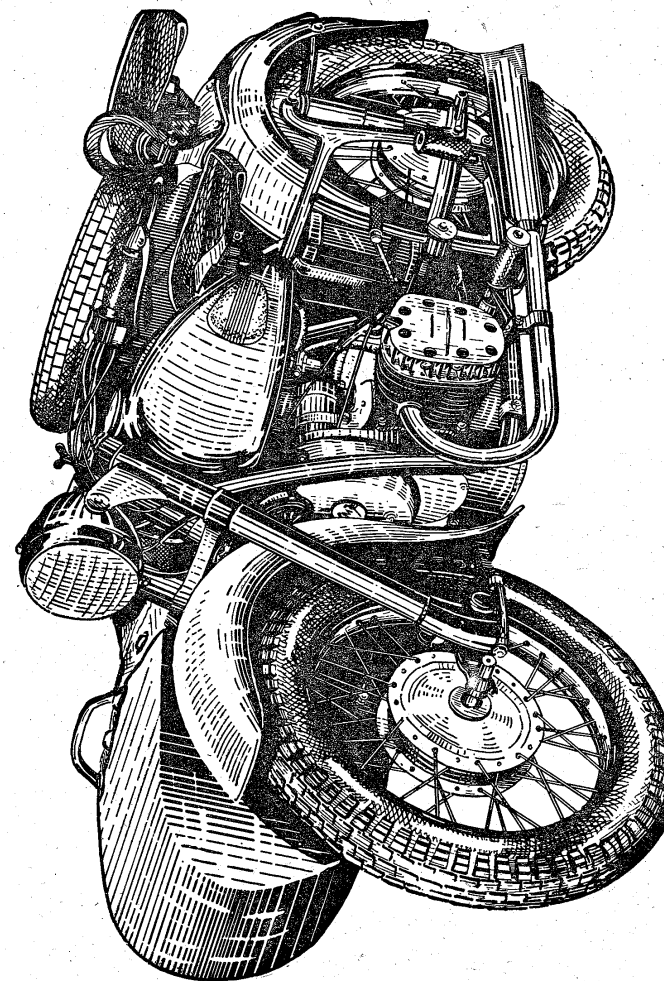

Fig. 2. General (left-hand) view of the motorcycle.

INDEX TO PART I

ASSEMBLIES, UNITS AND PARTS OF THE K-750 MOTORCYCLE

Group	Description	Page	Group	Description	Page
75001	Engine		7210	Petrol tank	40
	Crankcase with covers and oil pan . . .	13	7211	Handle bar	43
	Crank unit	15		Cables and cable sheaths	43
	Cylinders	17		Rear brake drive	46
	Valve timing gear	18	72H12	Exhaust pipes and silencers	46
	Cylinder heads	19		Exhaust pipes	46
	Oil pump	19		Silencers	46
7203	Clutch		5313	Front saddle	46
	Clutch release unit	20	5314	Rear saddle, assembled	48
7204	Gear box		7215	Carburettors, corrector, air cleaner	49
	Gear box case with covers	21		Corrector	49
	Shafts and pinions	23		Air cleaner	50
	Gear shifting control	23	75017/18	Electrical equipment	50
	Starting unit	25		Electric ignition devices, parts and their fastenings	50
72H05	Rear wheel drive			Electrical equipment devices and their fastenings	53
	Rear wheel drive case with covers . .	28		Electrical wires and their fas- tenings	53
	Rear drive reduction gear	29	65020	Sidecar chassis with spring-hydraulic wheel suspension	55
	Cardan shaft	29		Sidecar frame braces with adjusting fork	55
72H06	Wheel			Sidecar fixing rear bracket, assembled	55
	Front wheel brake	32		Sidecar chassis	55
	Rear wheel brake	34		Sidecar electrical equipment . . .	56
5308	Front fork	34	65021	Sidecar body	56
72H09	Motorcycle frame	36		Sidecar body	56
	Frame with engine, sidecar and storage battery fastenings; also with rear suspension lever and support . . .	36	7224	Driver's tools	58
	Rear wheel suspension	38			
	Support and driver's footrests . . .	38			
	Frame shock absorber	38			
	Rear wheel mudguard	40			

INDEX TO PART II
FITTINGS MANUFACTURED BY OTHER WORKS

Group	Description	Page
	Electrical equipment and devices	63
	Cables	63
	Bearings	64
	Rubber seals	67
	Rubber tubes	67
	Rubber parts	68
	Asbestos parts	69
	Cork parts	69

Group	Description	Page
	Paper parts	69
	Paronite parts	70
	Felt parts	70
	Plastic parts	70
	Units produced by contractor works	71
	Springs	71

INDEX TO PART III
FASTENINGS

Group	Description	Page
	Hexagonal-headed bolt	72
	Hexagonal-headed clevis bolt	73
	Hexagonal-headed bolt with an opening in its core	73
	Cup-headed bolt with square underhead	74
	Countersunk-headed screw	74
	Half-countersunk-headed screw	74
	Cup-headed screw	75
	Bevel-pointed set screw	75
	Pointless set screw	76
	Plug	76
	Stud	76
	Hexagonal nut	77
	Hexagonal plain nut	78
	Hexagonal slotted nut	78

Group	Description	Page
	Washer	78
	Spring washer	79
	Spacer	80
	Circular key	80
	Cylindrical pin	80
	Cotter wire	80
	Split cotter	80
	Pin	81
	Cup-headed screw nail	81
	Countersunk-headed screw nail	82
	Cup rivet	82
	Countersunk-rivet	82
	Cup hollow rivet	83
	Wire nail	83
	Lubricator	83

CATALOGUE

PART I

ASSEMBLIES, UNITS AND PARTS OF THE K-750 MOTORCYCLE

Fig. №	Number of part or assembly	Description	Q'ty per group (unit)	Notes
1	2	3	4	5
		GROUP 75001 ENGINE		
	75001/04	Engine and gear box, assembled	1	B
	75001	Engine	1	B
		Crankcase with covers and oil pan		
3	72H01101	Crankcase	1	B
3	009403	Generator guard stud	1	
3	009305	Tappet guide slide bar fixing stud	2	
3	009407	Cylinders fixing stud bolt	4	
3	009508	Cylinders fixing stud bolt	8	
3	009411	Gear box fixing stud bolt	3	
3	250511	Gear box fixing nut	3	
3	252005	Gear box fixing nut washer	3	
3	008406-A	Stud bolt for fixing engine to frame plate	2	
3	013102	Plug	1	
3	7201102	Spacing tube	1	B
3	7201103	Oil pipe	1	B
3	7201104	Oil pipe plug	1	B
3	7201105	Spacing tube packing ring	2	B
3	7201106	Oil pump driving gear bush	1	B
3	7201107	Camshaft bush	1	B
	72H01108	Crankcase, assembled (assembly includes parts		

Fig. №	Number of part or assembly	Description	Q'ty per group (unit)	Notes
1	2	3	4	5
		72H01101, 7201102, 7201103, 7201104, 7201105, 7201106, 7201107, 008406-A, 009305, 009403, 009407, 009411, 009508, 013102)	1	B
3	7201110	Oil discharge front filter	1	B
3	7201112	Oil discharge rear filter	1	B
3	220078	Oil discharge filters fixing screw	4	
3	252153	Spring washer, for screw fixing oil discharge filters	4	
3	72H011-1	Cam box cap with studs (assembly includes parts 72H01116, 72011-3-A, 003203, 009209, 008416, 258612)	1	B
3	72H01116	Cam box cap	1	B ¹
3	008416	Crankcase front cover fixing stud	1	
3	221611	Screw for fixing cam box cap to crankcase	6	
3	221617	Screw for fixing cam box cap to crankcase	4	
3	258612	Set pin	2	
3	009209	Contact breaker cover holder stud	1	
3	003203	Oil seal housing fixing screw	4	

¹ Interchangeable only together with part 72H01166.

Continued

1	2	3	4	5
4	7201208	1 ГПЗ No. 822907 bearing cage	2	B
4	7201209	Roller	24	B
4	7201211-A	Rear crank disk	1	B
4	7201213	Oil catcher	2	B

1	2	3	4	5
	7201218-A-P1	Oil control piston ring of the 1st repair size (increased by 0.2 mm)	4	B
	7201218-A-P2	Oil control piston ring of the 2nd repair size (increased by 0.5 mm)	4	B

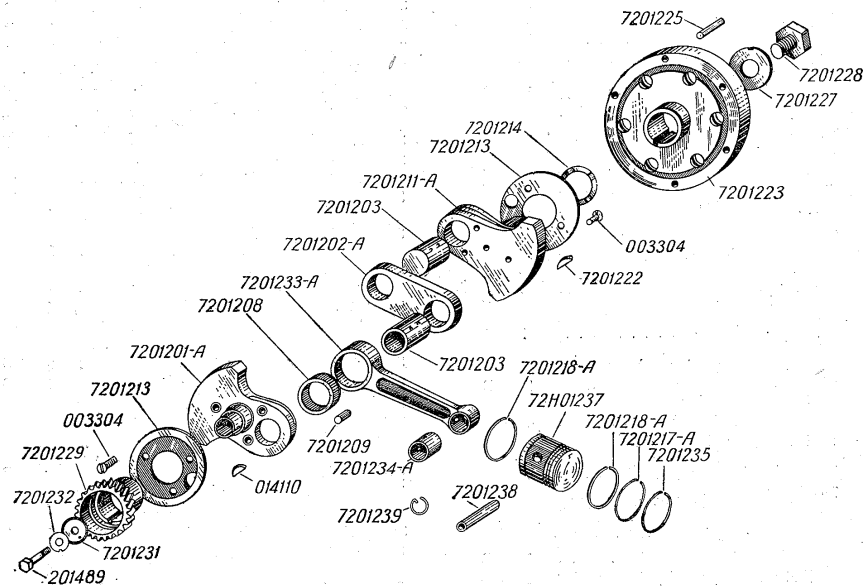

Fig. 4. Crankshaft with connecting rods and pistons.

4	003304	Oil catchers to crank disk fixing screw	6	
4	7201214	Spacing washer	1	B
4	7201217-A	Lower compression piston ring	2	B
	7201217-A-P1	Lower compression piston ring of the 1st repair size (increased by 0.2 mm)	2	B
	7201217-A-P2	Lower compression piston ring of the 2nd repair size (increased by 0.5 mm)	2	B
	7201217-A-P3	Lower compression piston ring of the 3rd repair size (increased by 1.0 mm)	2	B
4	7201218-A	Oil control piston ring	4	B

	7201218-A-P3	Oil control piston ring of the 3rd repair size (increased by 1.0 mm)	4	B
4	7201222	Flywheel semi-circular key	1	B
4	7201223	Flywheel	1	B
4	7201225	Coupling pin	6	B
4	7201227	Flywheel safety washer	1	B
4	7201228	Flywheel fixing bolt	1	B
4	7201229	Crankshaft distribution gear	1	B
	7201230	Flywheel with coupling pins (assembly includes parts 7201223, 7201225)	1	B
4	7201231	Crankshaft gear washer	1	B

Continued

1	2	3	4	5
4	7201232	Safety washer for the crankshaft distribution gear	1	B
4	201489	Crankshaft distribution gear fixing bolt	1	
4	7201233-A	Connecting rod	2	B
4	7201234-A	Connecting rod upper head bush	2	B
4	7201235	Chrome-plated top compression piston ring	2	B

1	2	3	4	5
4	014110	Semi-circular key	1	
4	72H01237	Piston	2	B
	72H01237-P1	Piston of the 1st repair size (increased by 0.2 mm)	2	B
	72H01237-P2	Piston of the 2nd repair size (increased by 0.5 mm)	2	B
	72H01237-P3	Piston of the 3rd re-		

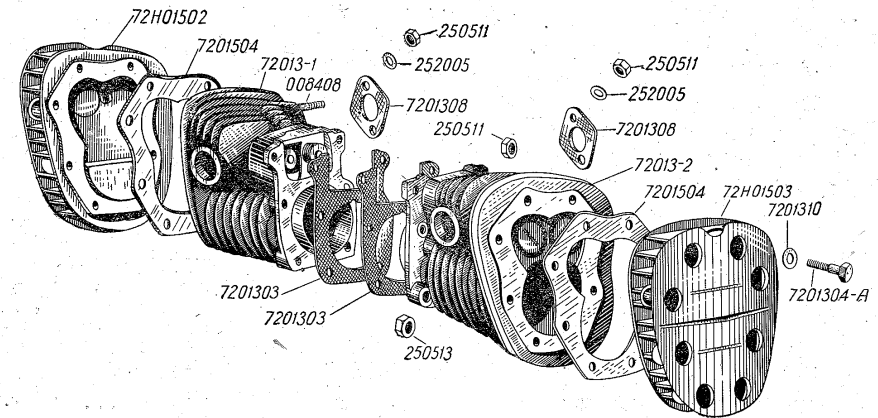

Fig. 5. Cylinders and cylinder heads.

	7201235-P1	Chrome-plated top compression piston ring of the 1st repair size (increased by 0.2 mm)	2	B
	7201235-P2	Chrome-plated top compression piston ring of the 2nd repair size (increased by 0.5 mm)	2	B
	7201235-P3	Chrome-plated top compression piston ring of the 3rd repair size (increased by 1.0 mm)	2	B
	7201236-A	Connecting rod, assembled (assembly includes parts 7201233-A, 7201234-A)	2	B
	72H012-2	Piston with pin and rings, assembled (assembly includes parts 7201217-A, 7201218-A, 7201235, 72H01237, 7201238)	2	B

	7201238	Piston pin	2	B
	7201239	Piston pin circlip	4	B
	7201241-A	Crank mechanism assembly (assembly includes parts 7201201-A, 7201202-A, 7201203, 7201208, 7201209, 7201211-A)	1	B

Cylinders

	72013-1	Right-hand cylinder with valves (assembly includes parts 7201301, 7201416, 7201417, 7201418, 7201419, 7201421, 7201422, 008408)	1	B
	72013-2	Left-hand cylinder with valves (assembly includes parts 7201302, 7201416, 7201417,		

Continued

1	2	3	4	5
		7201418, 7201419, 7201421, 7201422, 008408)	1	B
	7201301	Right-hand cylinder	1	B
	7201302	Left-hand cylinder	1	B
5	008408	Carburetter fixing stud	4	
5	250511	Carburetter fixing stud nut	4	

1	2	3	4	5
6	72H01401	Camshaft	1	B
6	014107	Semi-circular key . .	1	
6	7201402-B	Camshaft flange . . .	1	B
6	No. 205 FOCT 8338-57	Single-row radial ball bearing	1	
6	003304	Camshaft flange fixing screw	2	

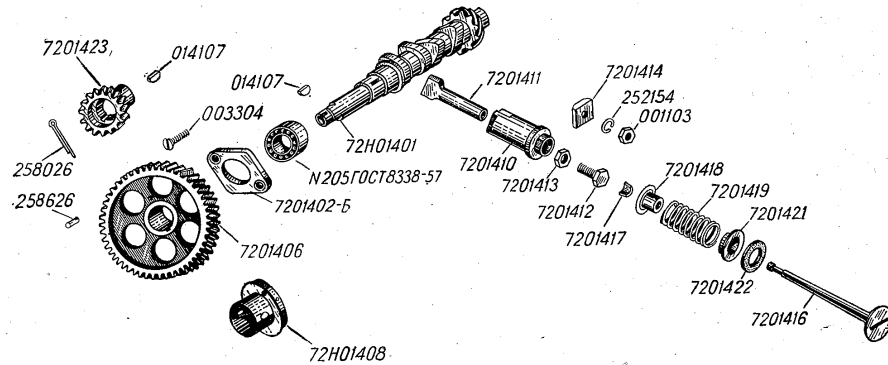

Fig. 6. Valve timing gear.

5	252005	Carburetter fixing stud rough washer	4	
5	7201303	Cylinder gasket . . .	2	B
5	250513	Cylinders fixing nut	8	
5	250511	Cylinders fixing nut	4	
5	7201304-A	Cylinder head fixing bolt	16	B
	7201306	Carburetter thin gasket	4	B
	7201307	Carburetter thick gasket	2	B
5	7201308	Carburetter gasket as- sembled (assembly in- cludes parts 7201306, 7201307)	2	B
5	7201310	Cylinder heads fixing bolt washer	16	B
	Valve timing gear			
	72H014-1	Camshaft gear, assem- bled (assembly includes parts 7201406, 258626)	1	B
	72H014-2	Camshaft with cam- shaft gear, assembled (as- sembly includes parts 72H01401, 7201402-B, 014107, No. 205 FOCT 8338-57, 7201406, 258626)	1	B

6	7201406	Camshaft gear . . .	1	B
6	258626	Camshaft gear pin .	1	
6	72H01408	Breather	1	B
6	72014-3	Tappet guide with tappet, assembled (assembly includes parts 7201410, 7201411, 7201412, 7201413) . . .	4	B
6	7201410	Tappet guide	4	B
6	7201411	Tappet	4	B
6	7201412	Tappet adjusting bolt	4	B
6	7201413	Tappet bolt lock nut	4	B
6	7201414	Tappet guide slide bar	2	B
6	001103	Tappet guide slide bar fixing nut	2	
6	252154	Tappet guide slide bar fastening spring washer	2	
6	7201416	Valve	4	B
6	7201417	Valve spring slide block	8	B
6	7201418	Lower valve collar . .	4	B
6	7201419	Valve spring	4	B
6	7201421	Upper valve retainer	4	B

Continued

1	2	3	4	5
6	7201422	Valve spring thickening washer	4	B
	72011-7	Generator with pini- on, assembled (assembly includes parts 72181-A, 7201423, 014107, 258026)	1	B
6	7201423	Generator pinion . .	1	B
6	014107	Semi-circular key . .	1	
6	258026	Generator pinion fix- ing split cotter	1	

Cylinder heads				
5	72H01502	Right-hand cylinder head	1	B
5	72H01503	Left-hand cylinder head	1	B
5	7201504	Cylinder head gasket	2	B

Oil pump				
	72016-1	Oil pump, assembled (assembly includes parts 7201602, 7201603, 7201604, 7201606, 7201607, 7201608-A) . .	1	B

7	7201601	Oil pump drive gear	1	B
7	7201602	Oil pump housing . .	1	B
7	7201603	Oil pump body cover	1	B
7	7201604	Driving gear for oil pump	1	B
7	7201606	Oil pump pinion . .	1	B
7	7201607	Oil pump body cover fixing bolt	2	B
7	7201608-A	Driving gear joint sle- eve	1	B
7	7201609	Driving gear connec- ting plunger	1	B
7	258013	Split cotter fixing oil pump connecting plun- ger	1	
7	7201611	Oil pump body gasket	1	B
7	019319	Oil pump to crankcase fixing bolt	2	
7	252154	Spring washer of oil pump filter fastening .	2	
7	7201618-A	Oil pump filter . . .	1	
7	258222	Cotter wire (0.8 mm diameter, 100 mm long) of the bolts fixing oil pump body cover	1	

GROUP 7203

CLUTCH				
8	7203101	Clutch disk	2	B
8	7203102	Clutch disk friction li- ning	4	B

1	2	3	4	5
8	7203106	Cogged rivet for driven clutch disk friction li- ning	24	B

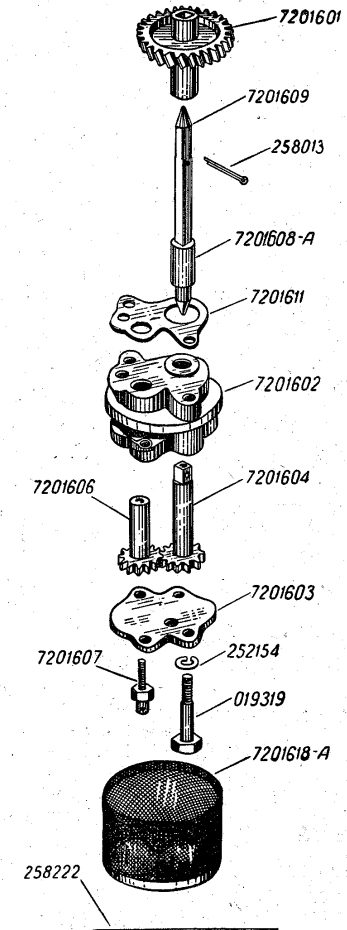

Fig. 7. Oil pump.

Continued

1	2	3	4	5
8	7203108	Driven clutch disk hub	2	B
8	253553	Driven clutch disk hub rivet	16	
8	7203109	Driven clutch disk oil deflector	1	B

1	2	3	4	5
		Clutch release unit		
	72032-1	Clutch operating lever with bracket (assembly includes parts 7203202, 7203203, 7203205, 7203123)		

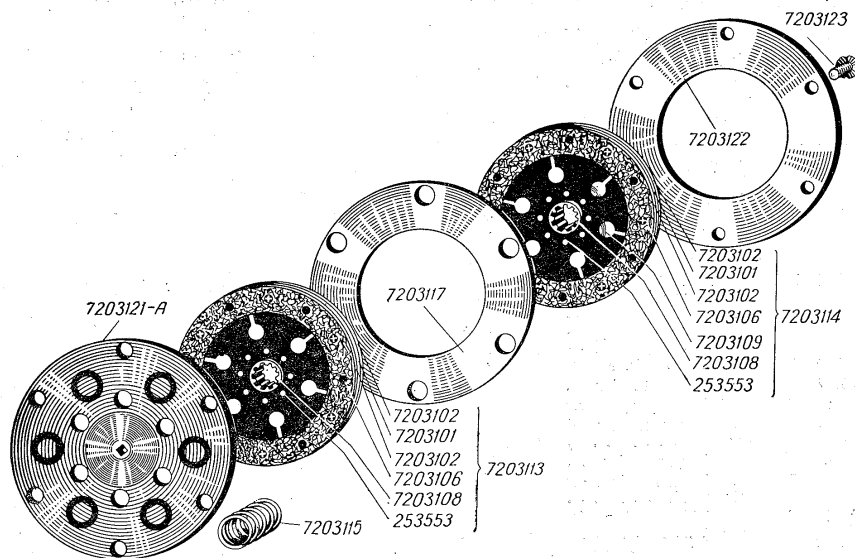

Fig. 8. Clutch.

	7203113	Driven clutch disk assembled (assembly includes parts 7203101, 7203102, 7203106, 7203108, 253553)	1	B
8	7203114	Clutch disk with oil deflector, assembled (assembly includes parts 7203101, 7203108, 7203109, 253553)	1	B
8	7203115	Clutch pressure spring	6	B
8	7203117	Intermediate driving clutch disk	1	B
8	7203121-A	Driving clutch pressure disk	1	B
8	7203122	Clutch pressure back disk, driving	1	B
8	7203123	Clutch driving thrust disk screw	6	B

		019315, 252004, 001103, 258013)	1	B
9	7203202	Clutch release lever bracket	1	B
9	019315	Clutch release lever bracket bolt	1	
9	252004	Clutch release lever bracket fixing bolt rough washer	1	
9	001103	Clutch release lever bracket fixing bolt nut	1	
9	7203203	Clutch release lever finger	1	B
9	258013	Clutch release lever finger split cotter	1	
9	7203205-A	Clutch release lever	1	B
9	7203206	Clutch release slide block	1	B

20

Continued

1	2	3	4	5
9	7203207	Clutch release guide block ring	1	B
9	7203209	Thrust ball bearing without rings	1	B
9	7203211	Clutch release rod-end	1	B
9	7203212	Clutch engagement rod	1	B
9	7203213	Clutch release rod gland	1	B
	7203214	Clutch release rod with gland, assembled (assembly includes parts 7203212, 7203213)	1	B
		GROUP 7204		
		GEAR BOX		
	7204	Gear box, assembled	1	B
		Gear case with covers		
	72041-1	Gear case, assembled (assembly includes parts 7204101-B, 7204102, 7204103, 7204157, 7204311, 7204327, 7204418, 7204419-B, 7204421, 003204, 003304, No. 304 GOCT 8338-57)	1	B
10	7204101-B	Gear case	1	B
10	7204102	Primary shaft rear bearing housing	1	B
10	7204103	Starting unit pawl release	1	B
10	003304	Starting unit release pawl fixing screw	1	
10	No. 304 GOCT 8338-57	Secondary shaft single-row radial ball bearing	2	
10	72041-2-B	Gear case front cover, assembled (assembly includes parts 7204107-B, 7204151, 258640)	1	B
10	7204107-B	Gear case front cover	1	B
10	258640	Gear case front cover pin	2	
10	019309	Gear case front cover fixing bolt	7	
10	252004	Front cover fixing bolt rough washer	7	
10	7204109-B	Gear case right-hand cover	1	B
10	004304	Gear box right-hand cover fixing screw	6	
	72041-4-B	Gear case left-hand cover, assembled (assembly includes parts 7204018, 7204114, 7204116, 7204117, 7204141, 7204142)	1	B

1	2	3	4	5
	7204018	Gear case left-hand cover with bushings (assembly includes parts 7204113-B, 7204115-B, 7204118)	1	D
10	7204113-B	Gear shifting foot pedal bushing	1	B
10	7204114	Oil seal housing	1	B
10	7204115-B	Gear-case left-hand cover	1	B
10	7204116	Oil seal ring	1	B
10	7204117	Gear shifting mechanism back-moving spring stop	1	B
10	7204118	Pawl crank bushing	1	B
10	019309	Gear case left-hand cover fixing bolt	4	
10	252004	Gear case left-hand cover fixing bolt rough washer	4	
10	264072	Gear case left-hand cover oiler	1	
10	7204119-B	Front bushing for the shaft of starting mechanism	1	B
10	003304	Starting mechanism shaft front bushing fixing screw	2	
10	7204121	Starting mechanism shaft rear bushing	1	B
10	004206	Starting mechanism shaft rear bushing fixing screw	4	
10	7204122-A	Starting mechanism shaft oil seal	1	B
10	7204125-B	Starting mechanism shaft oil seal spring	1	B
10	7204126	Starting mechanism shaft oil seal washer	1	B
10	7204127	Gear box case front cover gasket	1	B
10	7204128	Gear box case right-hand cover gasket	1	B
10	7204129	Gear box case left-hand cover gasket	1	B
10	7214131	Starting mechanism shaft front bushing gasket	1	B
10	7204132	Secondary shaft front bearing cover gasket	1	B
10	7204134-B	Secondary shaft front bearing cover flange	1	B
10	003304	Secondary shaft front bearing cover flange fixing screw	4	
10	7201134 A	Drain and filler oil plug	2	B

21

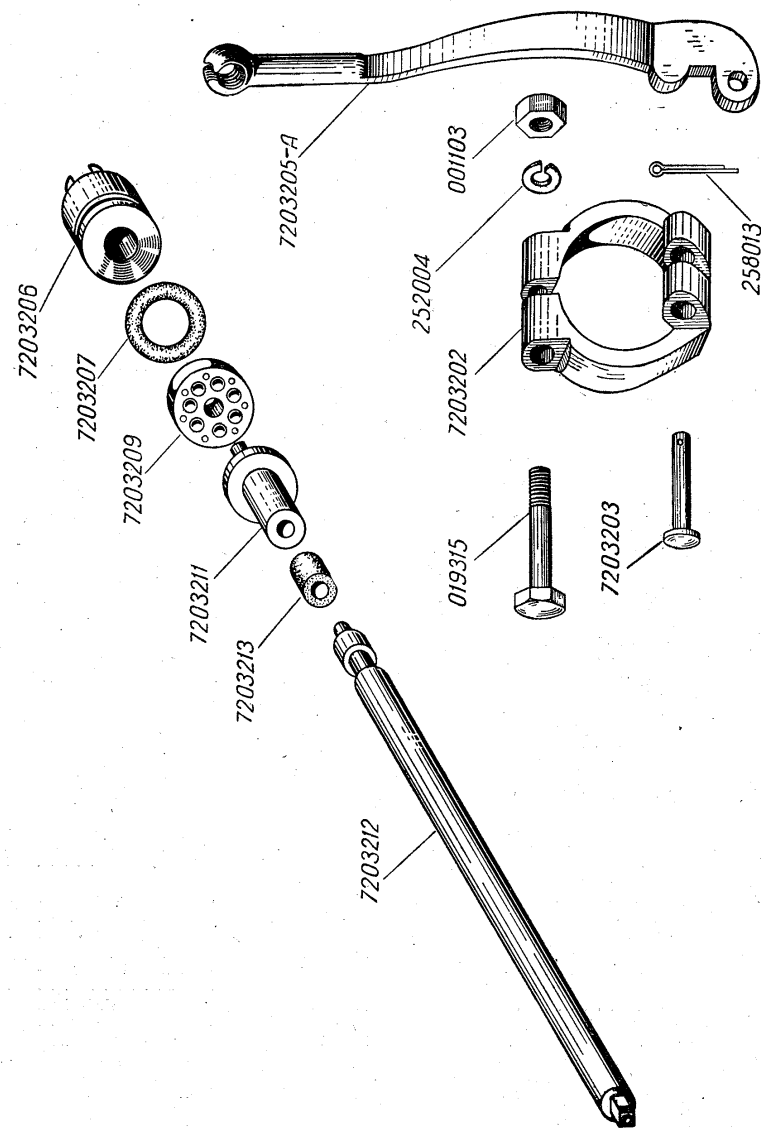

Fig. 9. Clutch release unit.

Continued

1	2	3	4	5	1	2	3	4	5	
10	011407	Copper spacer	2				7204221, 7204222, 7204224-B, 7204226, 7204236)	1	B	
10	7204137-B	Secondary shaft front bearing cover washer with tube	1	B	11	7204209	Secondary shaft low speed gear	1	B	
10	7204140	Starting mechanism shaft rear bushing gasket	1	B	11	7204211	Secondary shaft second speed gear	1	B	
10	7204141	Gear shifting pedal oil seal housing	2	B	11	7204212	Secondary shaft third speed gear	1	B	
10	7204142	Gear shifting pedal oil seal ring	2	B	11	7204213	Secondary shaft fourth speed gear	1	B	
10	7204144	Gear case felt packing	1	B	11	7204214	Secondary shaft low speed gear bushing	1	B	
10	258026	Felt packing split cotter	1		11	7204216	Secondary shaft second and third speed gear bushing	1	B	
10	7204146	Gear case right-hand cover oil seal, assembled (with spring)	1	B	11	7204217	Secondary shaft fourth speed gear bushing	1	B	
10	7204151	Primary shaft oil seal	1	B	11	7204218	Secondary shaft thrust ring	2	B	
10	7204157	Secondary shaft oil seal	1	B	11	7204219	Secondary shaft grooved bushing	1	B	
		Shafts and pinions			11	7204221	Clutch engaging 1st and 2nd gears	1	B	
		7204020	Primary shaft for gear box with pinion, bearings and oil-deflector (assembly includes parts 7204201, 7204202, 7204204, 7204205, 7204206, 7204207, 7204208, No. 2H12204 GOCT 8328-57, No. 205 GOCT 8338-57)	1	B	11	7204222	Clutch, engaging 3rd and 4th gears	1	B
11	7204201	Gear box primary shaft	1	B	11	7204224-b	Secondary shaft oil-deflecting washer	2	B	
11	No. 205 GOCT 8338-57	Single-row radial ball bearing for gear box primary shaft	1		11	7204226	Semi-circular key	2	B	
11	7204202	Pinion of fourth gear for primary shaft	1	B	11	7204232	Speedometer drive thrust bushing	1	B	
11	7204204	Big oil-deflecting washer for primary shaft	1	B	11	7204233	Speedometer drive bushing fixing bolt	1	B	
11	7204205	Primary shaft front bearing washer	1	B	10	7204234	Secondary shaft adjusting washer	3	B	
11	7204206	Small oil-deflecting washer for primary shaft	1	B	11	7204236	Gear box secondary shaft	1	B	
11	7204207	Semi-circular key	1	B	11	7204237	Secondary shaft nut	1	B	
11	7204208	Primary shaft clutch	1	B	11	258041	Secondary shaft nut split cotter	1		
11	No. 2H12204 GOCT 8328-57	Radial roller bearing with short cylindrical rollers	1		11	7204240	Driving disk for flexible clutch of cardan shaft	1	B	
		72042-2	Secondary shaft, for gear box, with pinions (assembly includes parts 7204209, 7204211, 7204212, 7204213, 7204214, 7204216, 7204217, 7204218, 7204219,			11	7204245	Speedometer drive gear	1	B
							Gear shifting control			
						7204019	Right-hand gear shifting box cover with selector plate and lever, assembled (assembly includes parts 7204109, 7204146, 7204303, 7204312, 7204313, 7204316, 7204317, 001102, 252003)	1	B	
					12	7204303	Selector plate with shaft	1	B	

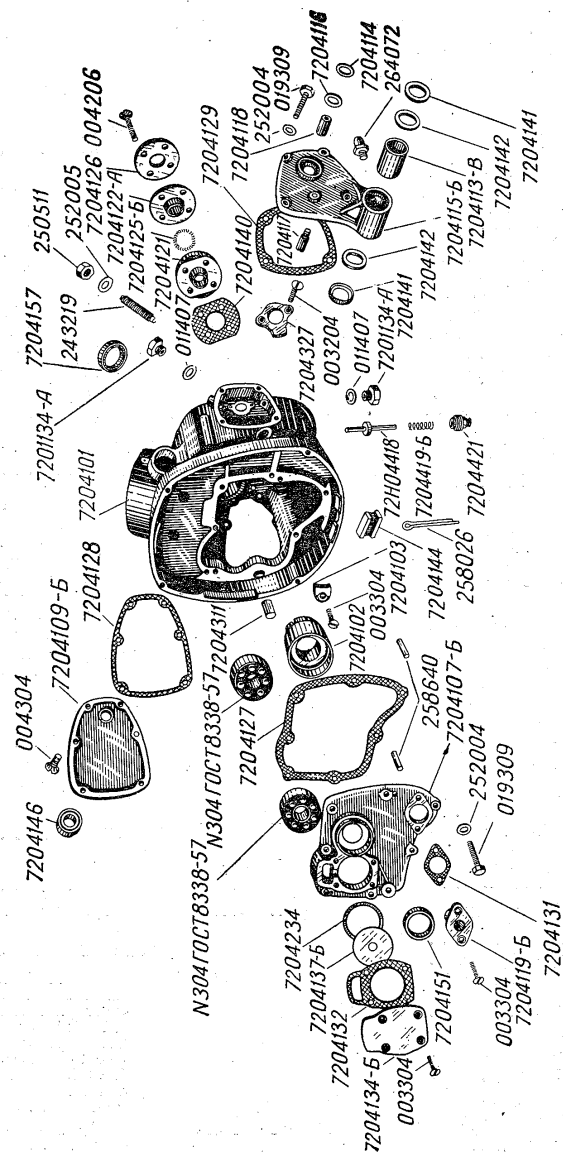

Fig. 10. Gear box housing with covers.

1	2	3	4	5	1	2	3	4	5
12	7204304	Fork for 1st and 2nd gear shifting	1	B	10	250511	Nut for the screw fixing the crank stop of gear shifting control pawls	2	
12	7204306	Fork for 3rd and 4th gear shifting	1	B	10	252005	Rough washer for the screw fixing the crank stop of gear shifting control pawls	2	
12	7204307	Shaft of gears shifting forks	1	B	12	7204334	Semi-circular key for the lever of gear shifting control pawls	1	B
12	242221	Screw for fixing the shaft of gear shifting forks	1		12	7204341-B	Gear shifting foot pedal washer	1	B
10	7204311	Lock for gear shifting selector (with built-in ball)	1	B	12	7204342	Lever for crank of gear shifting control pawls	1	B
12	7204312	Spring for the shaft of gear shifting selector	1	B	12	252156	Spring washer for the crank of gear shifting control pawls	1	
12	7204313	Washer for the shaft of gear shifting selector	1	B	12	250613	Nut for crank of gear shifting control pawls	1	
12	7204316	Shift lever	1	B	12	7204343-B	Gear shifting foot pedal, assembled	1	B
12	7204317	Shift lever clamping cotter	1	B	12	258053	Split cotter for gear shifting foot pedal	1	
12	001102	Clamping cotter nut	1				Starting unit		
12	252003	Rough washer for clamping cotter shift lever	1			72044-1-A	Starting unit shaft with pinion (assembly includes parts 7204407-A, 7204411, 7204412, 7204413)	1	B
	72043-1	Left-hand cover for gear box, with control for foot gear shifting (assembly includes parts 72041-4B, 7204324, 7204334, 7204342, 250613, 252156, 264072)	1	B	11	7204401-B	Starting unit shaft	1	B
12	7204318	Gear shifting control pawls crank	1	B	11	7204402-B	Starting unit pawl	1	B
12	7204319	Gear shifting control right-hand pawl	1	B	11	7204403	Starting unit pawl axle	1	B
12	7204321	Gear shifting control left-hand pawl	1	B	11	7204404	Starting unit pawl spring	1	B
12	7204322	Gear shifting control pawl axle	2	B	11	7204406	Starting unit pawl spring pin	1	B
12	7204323	Gear shifting control back-moving spring stop	1	B		7204407-A	Starting unit shaft with pawl and spring (assembly includes parts 7204401-B, 7204402-B, 7204403, 7204404, 7204406)	1	B
	7204324	Gear shifting control pawls crank with parts (assembly includes parts 7204318, 7204319, 7204321, 7204322, 7204323)	1	B	11	7204408	Starting unit pinion	1	B
12	7204326	Gear shifting control notch wheel	1	B	11	7204409	Starting unit pinion bushing	1	B
10	7204327	Gear shifting control pawls release	1	B		7204411	Starting unit pinion with bushing (assembly includes parts 7204408, 7204409)	1	B
10	003204	Screw for fixing release of pawls of gear shifting control	2		11	7204412	Starting unit shaft bushing	1	B
12	7204328	Gear shifting control pawls spring	1	B	11	7204413	Starting unit shaft bushing	1	B
12	7204329	Gear shifting control back-moving spring	1	B	11	7204414	Tapered pin with slot	1	B
12	7204331	Washer for crank of pawls of gear shifting control	1	B	11	7204417	Clamping cotter for the lever of starting unit	1	B
10	243219	Screw for fixing crank stop of gear shifting control pawls	2		11	250511	Starting unit key nut	1	

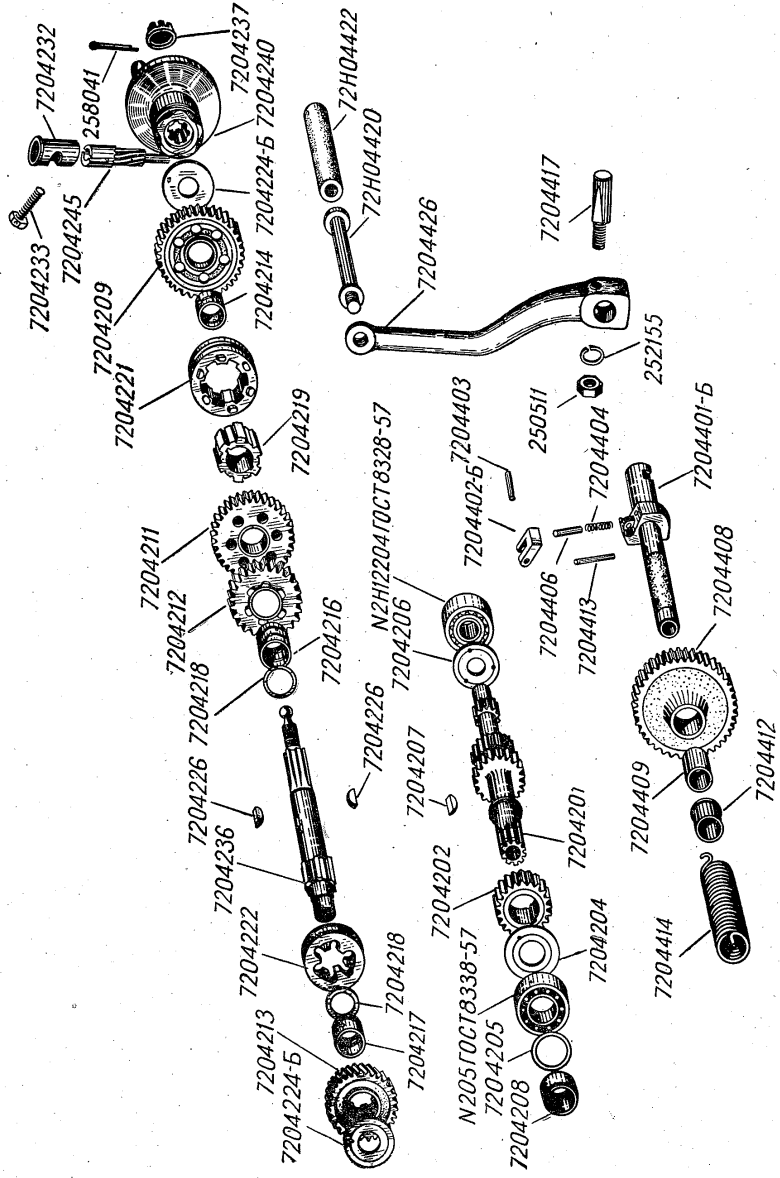

Fig. 11. Shafts and pinions of gear box.

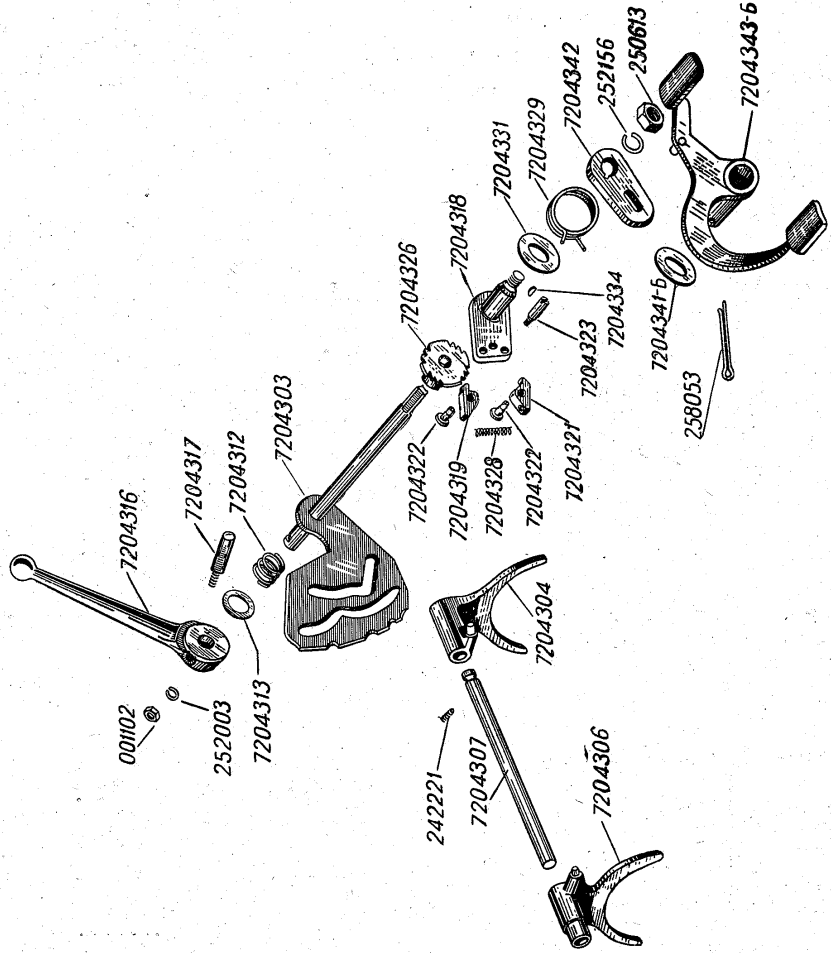

Fig. 12. Gear shifting unit.

Continued

1	2	3	4	5
11	252155	Spring washer for the key of starting unit	1	
10	72H04418	Pin for buffer of starting unit shaft	1	B
10	7204419-B	Starting unit shaft buffer spring	1	B

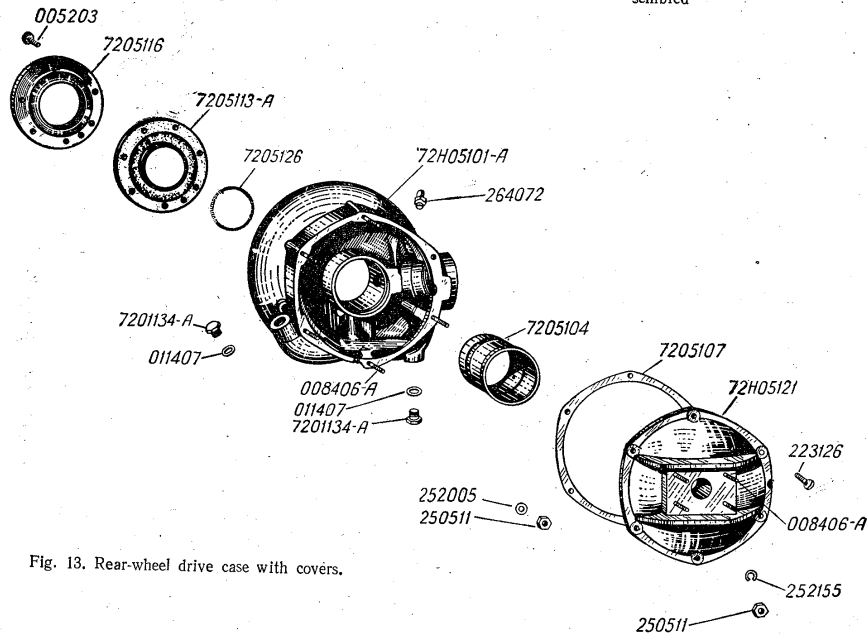

Fig. 13. Rear-wheel drive case with covers.

72H044-5	Starting unit lever, assembled (assembly includes parts 72H04420, 72H04422, 7204426)	1	B	
11	72H04420	Starter switch pedal	1	B
10	7204421	Starting unit shaft buffer plug	1	B
11	72H04422	Sleeve for pedal of starting unit lever	1	
11	7204426	Starter switch lever	1	B
GROUP 72H05				
REAR-WHEEL DRIVE				
72H05-A	Rear-wheel drive, assembled, with brake (assembly includes parts			

1	2	3	4	5
		72H05-1-A, 7206223-A, 5306250, 5306260, 5306271, 5306272, 5306273)	1	
	72H05-1-A	Rear-wheel drive, assembled		

Rear-wheel drive case with covers				
72H05012-A	Rear-wheel drive case, with driving gear, assembled (assembly includes parts 7205011, 72H05106-A, 72052-3, 7205214, 7205224)	1		
13	72H05101-A	Rear-wheel drive case	1	
13	7205104	Rear-wheel drive case bushing	1	B
	72H05106-A	Rear-wheel drive case, assembled (assembly includes parts 72H05101-A, 7205104, 5306206-A, 252154, 201418, 264072, 008406-A)	1	

Continued

1	2	3	4	5
13	7205107	Rear-wheel drive case cover gasket	1	B
13	7205113-A	Oil seal follower of rear-wheel drive case	1	B
13	7205116	Oil seal cover of rear-wheel drive casing	1	B
13	005203	Oil seal cover fixing screw	7	
13	72H05121	Rear-wheel drive case cover	1	
13	223126	Rear-wheel drive cover fixing screw	1	
13	008406-A	Rear-wheel drive cover fixing stud	5	
13	250511	Rear-wheel drive cover fixing nut	5	
13	252005	Rough washer for stud fixing the cover of rear-wheel drive	5	
	72H05122	Rear wheel drive case cover, assembled (assembly includes parts 72H05121, 008406-A)	1	
13	008406-A	Stud for fixing lever of rear-wheel suspension	4	
13	250511	Lever fixing-nut of rear-wheel suspension	4	
13	252155	Spring washer for the stud fixing the lever of rear-wheel suspension	4	
13	7205126	Oil seal spring of rear-wheel drive case	1	B
13	7201134-A	Drain plug	2	B
13	011407	Drain and filler plug spacer	2	
13	264072	Brake cam lubricator	1	

Rear drive reduction gear

7205011	Driving gear with bearings, assembled (assembly includes parts 72052-1, 72052-2, 7205202-B)	1	B	
14	7205202-B	Rear-wheel drive gear ¹	1	B
14	72052-1	Needle bearing	1	B
14	72052-2	Double-row radial-thrust ball bearing	1	B
	72052-3	Bearing nut of rear-wheel drive, assembled (assembly includes parts 7205033, 7205223)	1	B
14	7205223	Rear-wheel drive bearing nut	1	B

¹ It is advisable to order part 7205202-B in assembly with part 7205227-B as these pinions are run-in two at a time at the works, which ensures their noiseless operation.

1	2	3	4	5
14	7205224	Rear-wheel drive bearing nut washer	1	B
	72052-4	Rear-wheel drive pinion, assembled (assembly includes parts 7205227-B, 7205229, 7205248, 019403, No. 207 GOCT 8338-57)	1	B
14	No. 207 GOCT 8338-57	Single-row radial ball bearing	1	
14	7205227-B	Rear-wheel drive pinion	1	B
14	7205229	Pinion hub	1	B
14	019403	Pinion to hub fixing bolt	8	
14	7205233	Spacing ring, 1.7 — 1.6 mm thick ²		B
14	7205234	Spacing ring, 1.8 — 1.69 mm thick ²		B
14	7205235	Spacing ring, 1.2 — 1.12 mm thick ²		B
14	7205236	Spacing ring, 2.0 — 1.89 mm thick ²		B
14	7205237	Spacing ring, 1.5—1.41 thick ²		B
14	7205238	First bearing liner for pinion hub of rear-wheel drive	1	B
14	7205239	Second bearing liner for pinion hub of rear-wheel drive	1	B
14	7205241	Adjusting washer, 0.08—0.07 mm thick ³		B
14	7205242	Adjusting washer, 0.18—0.16 mm thick ³		B
14	7205243	Adjusting washer, 0.3—0.27 mm thick ³		B
14	7205246-A	Spacing sleeve	1	B
14	7204142	Gear shifting pedal oil seal ring ⁴	1	
14	7205248	Special safety washer	4	B

Cardan shaft

72H053-1	Cardan shaft with joint, assembled (assembly includes parts 72H05301, 7205304, 7205306-B, 7205309,)		
----------	---	--	--

² The number and thickness of the ring are chosen while assembling. After mounting one of the rings, make sure, that the clearance between the ends of the bushing of rear-wheel drive casing and the hub is about 0.15 to 0.30 mm.

³ The number and thickness of the washers are chosen while assembling. After mounting one of the washers, the clearance between the ends of the bushing of rear-wheel drive casing and the hub should be equal from 0.15 to 0.30 mm.

⁴ Used as oil seal for spacing sleeve 7205246-A.

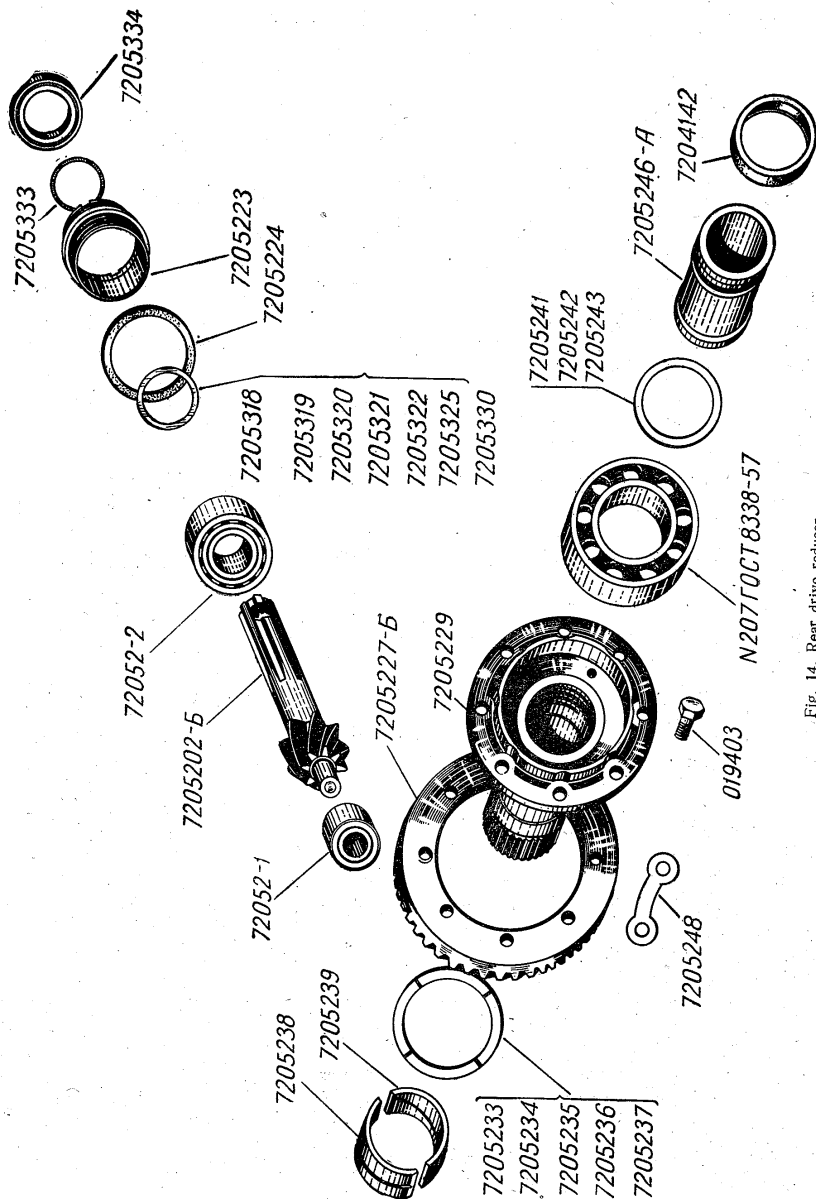

Fig. 14. Rear drive reducer.

1	2	3	4	5
---	---	---	---	---

15	72H05301	7205311, 7205312, 7205313, 7205317, 72053-2, 264072)	1	B ¹
15	7205304	Cardan shaft	1	B
15	7205306-B	Universal-joint casing, assembled	1	B
15	72H05307	Cardan shaft packing ring	1	B
15	7205309	Elastic cardan disk	1	B
15	7205311	Universal-joint splined fork	1	B
15	264072	Cardan shaft lubricator	1	B

1	2	3	4	5
---	---	---	---	---

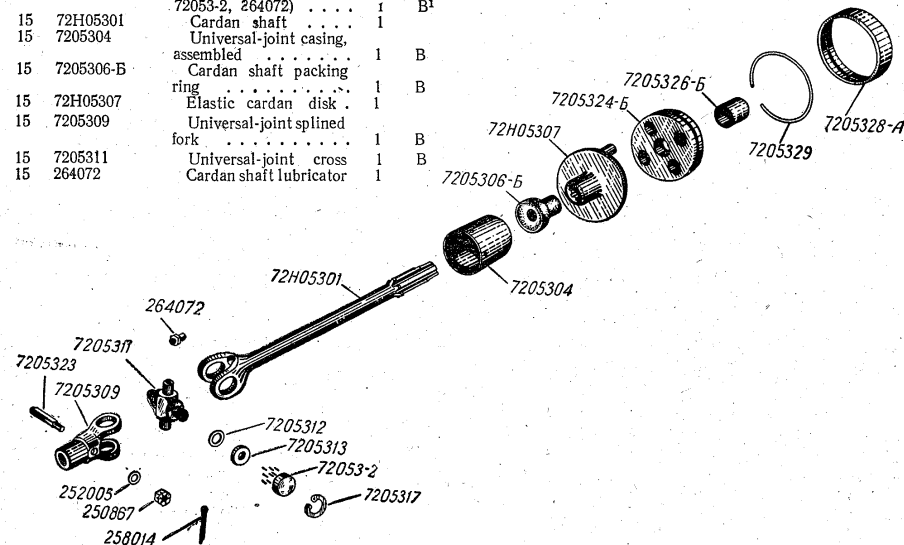

Fig. 15. Cardan shaft.

15	7205312	Cardan shaft packing ring	4	B
15	7205313	Packing ring of cardan shaft housing	4	B
15	72053-2	Needle bearing	4	B
15	7205317	Cardan shaft circlip	4	B
14	7205318	Adjusting washer, 0.8—0.73 mm thick ²	4	B
14	7205319	Adjusting washer, 0.95—0.88 mm thick ²	4	B
14	7205320	Adjusting washer, 0.4—0.36 mm thick ²	4	B
14	7205321	Adjusting washer, 1.05—0.96 mm thick ²	4	B
14	7205322	Adjusting washer, 1.15—1.06 mm thick ²	4	B
14	7205325	Adjusting washer, 0.55—0.5 mm thick ²	4	B
14	7205330	Adjusting washer, 0.70—0.65 mm thick ²	4	B

15	7205323	Clamping cotter	1	B
15	250867	Clamping cotter fixing nut	1	B
15	252005	Clamping cotter rough washer	1	B
15	258014	Clamping cotter split cotter	1	B
	7205013	Elastic cardan clutch, assembled (assembly includes parts 7205324-B, 7205326-B, 7205328-A, 7205329)	1	B
15	7205324-B	Elastic cardan clutch	1	B
15	7205326-B	Elastic cardan clutch bushing	1	B

¹ Interchangeable in assembly with part 72H05307.

² The number and thickness of the washer is chosen while assembling.

³ The number and thickness of the washers are chosen while assembling. After mounting one of the washer the end of the clamping cotter should not be flushed deeper than the surface of the cardan fork boss.

Continued

1	2	3	4	5
15	7205328-A	Elastic cardan housing	1	B
15	7205329	Elastic cardan housing circlip	1	B
	7205033	Cardan fork oil seal, assembled (assembly includes parts 7205333, 7205334)	1	B
14	7205333	Cardan fork oil seal spring	1	B
12	7205334	Cardan fork oil seal cup	1	B
GROUP 72H06				
Wheel				
	72H06-1	Wheel with tyre, assembled (assembly includes parts 72H061-1, 7206123, 7206124, 7206126)	1 ¹	B
	72H061-1	Wheel, assembled (assembly includes parts 7206109, 5306110, 5306120, 5306130, 5306141, 5306143, 5306144, 72H06151, 5306152, 72H06153, No. 7204 GOCT 333-55, 264072)	1	B
16	5306010	Hub guard (oil deflector), assembled	1 ²	
16	7207101	Rear wheel axle	1	B
16	367202	Rear wheel axle nut	1	
16	258026	Rear wheel axle split cotter	1	
16	7206109	Thrust washer	1	B
16	5306110	Wheel body (with steel hub and brake drum)	1	
	5306120	Hub nut, assembled (assembly includes parts 5306121, 5306125)	1	
16	5306121	Hub special nut	1	
16	7206123	Tyre flap 3.75-19 GOCT 5652-51	1	B
16	7206124	Tyre tube 3.75-19 GOCT 5652-51	1	B
16	5306125	Oil seal, assembled (with spring)	1	
16	7206126	Tyre protector 3.75-19 GOCT 5652-51	1	B
16	7206127	Front wheel axle	1	B
16	5306130	Spacing sleeve, assembled	1	
16	5306141	Special round nut 4M52 x 1	1	
16	5306143	Left-hand spacing sleeve	1	
16	5306144	Right-hand spacing sleeve	1	

¹ The motorcycle with a sidcar is supplied with four wheels (two wheels for motorcycle, one wheel for sidcar, and a spare wheel).

² The spare wheel is not supplied with the guard.

1	2	3	4	5
16	72H06151	Spoke type A-M5 GOCT 3228-55	40	
16	5306152	Nipple M5 GOCT 3228-55	40	
16	72H06153	Wheel rim 484 x 55 GOCT 3188-55	1	B
16	No. 7204 GOCT 333-55	Taper roller bearing	2	
16	264072	Wheel housing lubricator	1	
Front wheel brake				
	5306-2	Front wheel brake, assembled (assembly includes parts 5306200, 5306210, 5306218, 5306222, 7206223-A, 5306224, 5306235, 5306250, 5306260, 5306271, 5306272, 5306273, 5306274, 252156, 250513)	1	
	5306200	Front brake disk, assembled (assembly includes parts 5306202, 5306206, 5306215, 5306216, 264072, 201418, 252154)	1	
17	5306202	Front wheel disk (with lever)	1	
17	5306206	Bracket	1	
	5306210	Wheel axle bushing, assembled (assembly includes parts 5306212, 5306214)	1	
17	5306212	Wheel axle bushing	1	
17	5306214	Wheel axle bushing cup	1	
17	5306215	Front brake disk oil seal	1	
17	5306216	Front brake disk bushing	2	
17	75006217	Brake lining rivet	18	B
17	5306218	Spacing washer	1	
17	5306222	Thrust washer	1	
17	7206223-A	Brake shoe spring	2	B
17	5306224	Circlip	1	
	5306235	Reactive lever, assembled (assembly includes parts 5306240, 5306245)	1	
17	5306240	Pin with bushing, assembled	2	
17	5306245	Reactive lever	1	
17	5306250	Brake shoe, assembled (assembly includes parts 75006217, 5306251, 5306255)	2	
17	5306251	Strap	2	
17	5306255	Brake shoe	2	

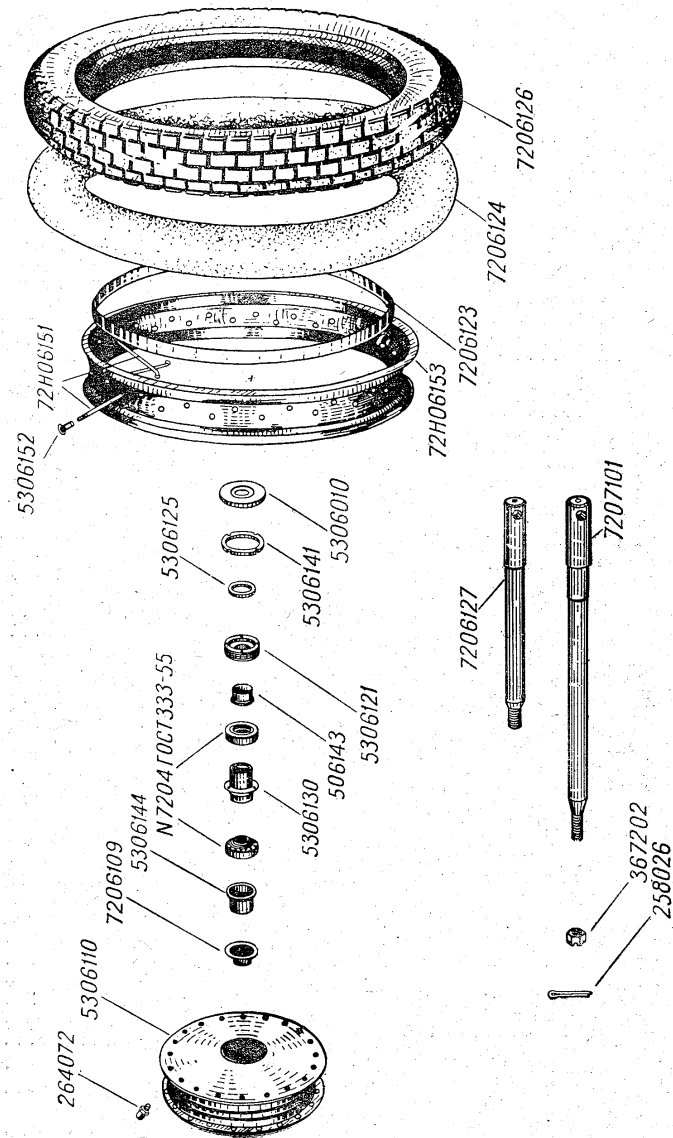

Fig. 16. Wheel with its hub.

1	2	3	4	5
18	250513	Cross-member stretching bolt	2	
18	010505	Cross-member stretching bolt rough washer	4	
18	5308173	Steering column rod washer	1	
18	5308174	Steering column rod special nut 2M27	1	
18	5308180	Left-hand head lamp bracket, assembled	1	
18	5308190	Right-hand head lamp bracket, assembled	1	
18	5308194	Head lamp bracket thickening ring	2	
18	5308196	Fork tube plug	2	
18	5308200	Left-hand suspension arm, assembled	1	
18	5308203	Bolt 1M8 × 32	1	
18	252150	Spring washer for stretching suspension arm bolt	1	
18	5308206-A	Internal lever	1	
18	5308208-A	Special adjusting screw 1M8 × 20	2	
18	5308210	Right-hand suspension arm, assembled	1	
18	5308214	Special internal washer 24.5 mm in diameter	2	
18	5308216	Special internal washer 19.5 mm in diameter	2	
18	5308218-A	Suspension spring	2	
18	5308220-A	Guide tube with tip, assembled	2	
18	5308226	Shock absorber housing	2	
18	5308228	Gasket	2	
18	5308232	Front plug 1M20	2	
18	5308234-A	Rear plug 1M20	2	
18	5308236	Thickening washer	4	
18	5308238	Shock absorber spring	4	
18	5308240	Shock absorber valve, assembled	4	
18	5308242	Shock absorber piston	4	
18	019307	Shock absorber housing fixing bolt	12	
18	252004	Rough washer for the bolt fixing shock absorber housing	12	
18	5308300-B	Handlebar damper wing nut, assembled (assembly includes parts 5308305-B, 7208311, ball 7/32")	1	
	5308305-B	Handlebar damper wing nut	1	

1	2	3	4	5
18	5308311	Handlebar damper special nut	1	
18	7208311	Spring	2 B	
18	7208312	Ball bearing upper guard washer	1 B	
18	5308312	Handlebar damper lower washer	1	
18	5308316	Handlebar damper friction washer	2	
18	5308321-B	Handlebar damper washer with tongue	1	
18	5308326	Handlebar damper upper washer	1	
18	5308328	Handlebar spring	1	
18	258002	Rod of handlebar damper split cotter	1	
18	5308410	Ball 7/32" ГОСТ 3722-54	2 B	
18	5308410	Front wheel mudguard, assembled	1	
18	5308414	Union nut 1M8	2	
18	019405	Front mudguard fixing bolt	2	
18	250511	Front mudguard fixing bolt nut	2	
18	252155	Front mudguard fixing bolt spring washer	4	
GROUP 72H09				
MOTORCYCLE FRAME				
	72H09	Frame, assembled	1	
Frame with engine, sidcar and storage battery fastening; also, with rear suspension lever and support				
19	5309100	Frame	1	
19	264072	Steering column lubricator	2	
19	264072	Rear brake axle bearing lubricator	1	
19	019407	Silencers fixing bolt	2	
19	250511	Silencers fixing bolt nut	2	
19	252155	Silencers fixing bolt spring washer	2	
19	5309168	Engine fixing plate	1	
19	7209158	Sidcar middle brace bracket	2 B	
19	250515	Nut for fixing the bracket of sidcar brace	2	
19	252157	Bracket of sidcar middle brace spring washer	2	
19	252007	Engine fixing plate rough washer	1	
19	5309182	Passenger footrest	2	
19	5309183	Passenger footrest tube	2	
19	5309189	Special washer 25.5 × 40 × 2	4	

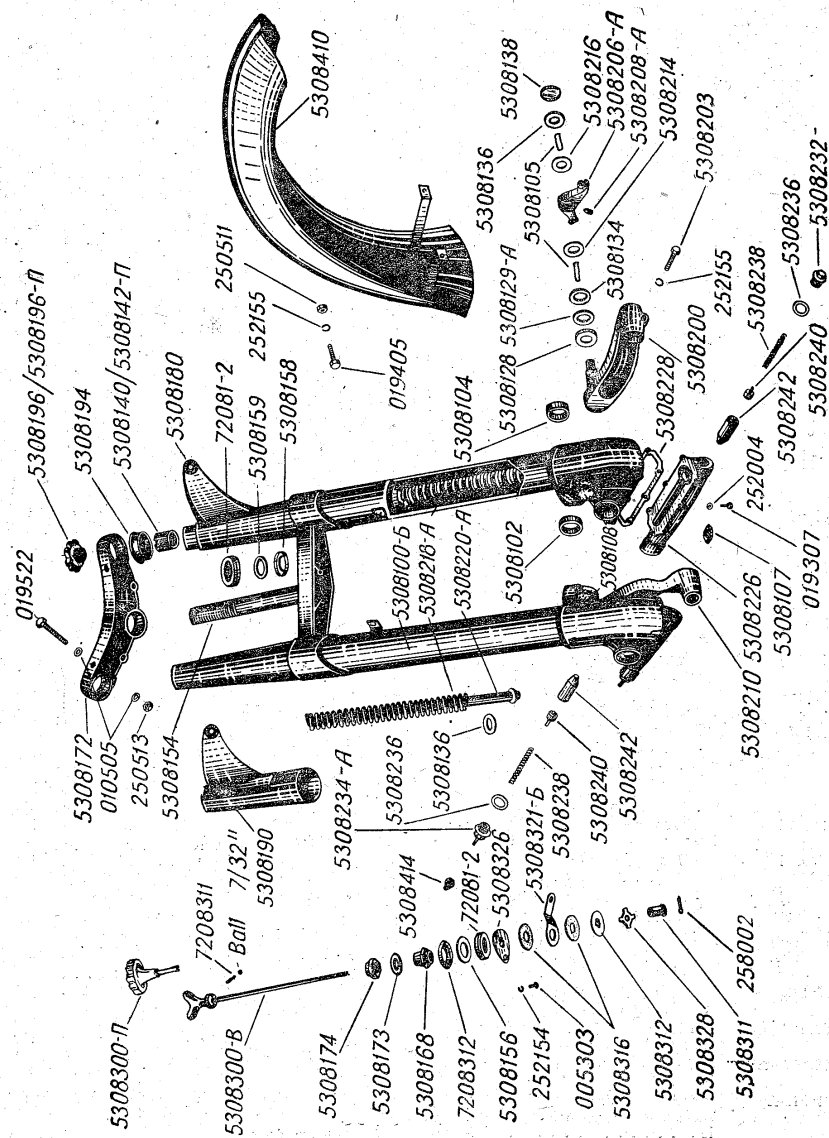

Fig. 18. Front fork.

Continued

1	2	3	4	5
19	260041	Passenger footrest-fixing pin	2	
19	252005	Passenger footrest fixing pin rough washer	2	
19	258014	Pin fixing the passenger footrest-split cotter	2	
19	7209168-B	Storage battery gasket	1	B
19	72H09173	Storage battery rear strap, assembled	1	
19	72H09176	Storage battery front strap, assembled	1	B
19	7222303	Wing nut	1	B
19	252004	Rough washer for storage battery fastening	1	
19	72H09189-B	Trade mark plate	1	
19	005101	Trade mark plate fixing screw	2	
19	7209163	Collar clamp	2	B
19	7209186	Stop long plate	1	B
19	7209187	Stop short plate	1	B
19	7209188	Stop collar	1	B
19	005209	Lever stop fixing screw	1	
19	001102	Screw nut fixing the starting mechanism lever stop	1	
19	72H09264	Sidcar front brace bracket	1	
19	72H09265	Bracket cover plate	1	
19	019610	Sidcar front brace bracket fixing bolt	1	
19	019615	Sidcar front brace bracket fixing bolt	1	
19	250515	Sidcar front brace bracket fixing bolt nut	1	
19	252157	Sidcar front brace bracket fixing bolt spring washer	2	
Rear wheel suspension				
19	5309200	Rear wheel suspension lever, assembled	1	
19	5309201	Silent block special washer	1	
19	5309231	Protective cup	2	
19	5309233	Special washer	2	
19	5309235	Detachable pivot	1	
19	019515-A	Pinch bolt for the pivot of suspension lever	2	
19	250513	Bolt nut fixing the pivot of suspension lever	2	
19	252156	Pivot suspension lever fixing bolt spring washer	2	
19	5309344-A	Metal sleeve with rubber	2	
19	019515-A	Bolt for fixing the shock absorber from below	2	

1	2	3	4	5
19	252156	Shock absorber fixing bolt spring washer	4	
19	019522	Bolt for fixing the shock absorber from above	2	
19	250513	Nut for fixing the shock absorber from above	2	
19	018509	Bolt fixing the lever of rear wheel suspension to frame	2	
19	252156	Suspension lever fixing bolt spring washer	2	
19	5309245	Special pinch bolt 1M8 x 42	1	
19	250511	Bolt nut for fixing the rear wheel axle	1	
19	252005	Rear wheel axle fixing bolt rough washer	1	
19	5309259	Silent block bushing	4	
Support and driver's footrests				
19	5309240-A	Motorcycle support, assembled	1	
19	7209314	Spacing washer	2	B
19	7209315	Support axle	1	B
19	252007	Support fastening rough washer	2	
19	258026	Support axle split cotter	2	
19	7209318-A	Support spring	1	
19	5309277	Engine fixing front stud, assembled	1	
19	5309282	Left-hand front spacing sleeve	1	
19	250515	Engine fixing stud nut	1	
19	252157	Spring washer of engine to frame fastening	1	
19	5309278	Rear stud 1M12 x 317 for fixing the engine	1	
19	5309279	Right-hand rear spacing sleeve	1	
19	5309281	Left-hand rear spacing sleeve	1	
19	250515	Engine fixing stud nut	2	
19	72093-2	Footrest with roller (assembly includes parts 7209301, 7209303-A)	2	B
19	7209301	Footrest roller	2	B
19	7209303-A	Footrest	2	B
Frame shock absorber				
19	5309300-A	Spring-hydraulic shock absorber, assembled	1	
20	5309310-B	Shock absorber body, assembled	1	

¹ The motorcycle with a sidcar is delivered with three shock absorbers (two for motorcycle frame and one for sidcar chassis)

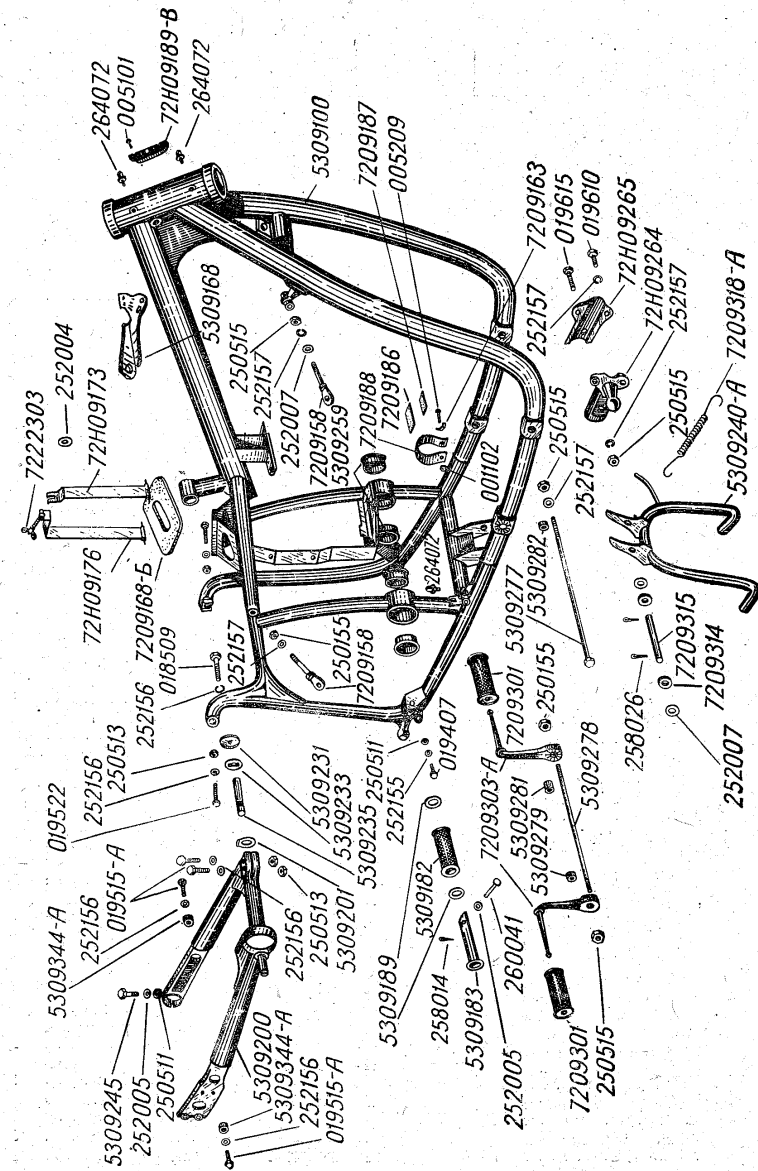

Fig. 19. Frame, prop and footrests.

Continued

1	2	3	4	5	1	2	3	4	5
	5309320	Rod, assembled (assembly includes parts 5309321, 5309322) . . .	1		21	019405	Bolt fixing the rear saddle bridge to the side of mudguard	2	
20	5309321	End nut	1		21	250511	Bolt nut fixing the saddle bridge to mudguard	6	
20	5309322	Rod	1		21	252155	Spring washer for the bolt fixing the passenger's saddle bridge to mudguard	6	
20	5309331-B	Lower housing	1		21	019409	Bridge to mudguard fixing bolt	4	
20	5309341	Spring	1		21	5309420	Hinged part of rear mudguard, assembled	1	
20	5309342	Upper housing	1		21	5309457	Special washer dia. 8.5 x 30 x 3	4	
20	5309343	Split wedge	2		21	5309458	Bolt washer gasket	2	
20	5309344-A	Spacing bushing with rubber	1		21	019409	Bolt fixing the braces of rear mudguard	2	
20	5309346	Safety valve	1		21	250511	Nut for the bolt fixing the braces of rear mudguard	2	
20	5309347	Safety valve spring	1		21	252155	Spring washer for the bolt fixing the braces of rear mudguard	2	
20	5309348	Upper valve spring	1		21	5309460	Number-plate bracket	1	
20	5309349	Gland spring	1		21	004206	Tail-lamp fixing screw	1	
20	5309350	Lower valve, assembled (assembly includes parts 5309346, 5309347, 5309352, 5308256)	1		21	005203	Tail-lamp fixing screw	2	
20	5309351	Lower valve housing	1		21	001102	Tail-lamp fixing screw nut	3	
20	5309352	Lower valve	1		21	252153	Tail-lamp fixing screw spring washer	3	
20	5309353	Special washer	1		21	005303	Number-plate fixing screw	2	
20	5309354	Shock absorber tube	1		21	001103	Number-plate fixing screw nut	2	
20	5309355	Upper bearing	1		21	252154	Number-plate fixing screw spring washer	2	
20	5309356	Thickening ring	1		21	252004	Number-plate fixing screw rough washer	2	
20	5309357	Special nut	1		21	005303	Screw fixing the bracket of numberplate	1	
20	5309358	Special washer	1		21	001103	Number-plate bracket fixing screw nut	1	
20	5309362	Oil seal	1		21	252154	Number-plate bracket fixing screw spring washer	1	
20	5309363	Bumper	2				GROUP 7210		
20	5309371	Shock absorber piston	1				PETROL TANK		
20	5309372	Special nut 1M8 x 1	1		22	7210	Petrol tank, assembled	1 B	
20	5309373	Upper valve	1		22	72103-A	Fuel cock	1 B	
20	5309375	Stop	1		22	7210129-B	Tool box cover hinge pin	2 B	
20	5309376	Special circlip	1		22	7210133	Tool box lock, assembled	1 B	
20	5309377	Lower valve spring	1		22	7210134	Tool box cover lock circlip	1 B	
20	5308256	Washer 2 mm in diameter	1		22	7210138-B	Knee grip plate	2 B	
					22	7210141-B	Knee grip	2 B	
		Rear wheel mudguard							
	5309400	Rear wheel mudguard, assembled (assembly includes parts 5309410, 5309420)	1						
21	5309405	Hinge pin	1						
21	5309410	Front part of rear mudguard, assembled	1						
21	019405	Rear mudguard to frame fixing bolt	1						
21	252155	Spring washer for the bolt fixing the rear mudguard to frame	2						
21	019407	Rear mudguard to frame fixing bolt	1						
21	250511	Bolt nut fixing the rear mudguard to frame	1						
21	5309465	Bridge with brackets, assembled	1						

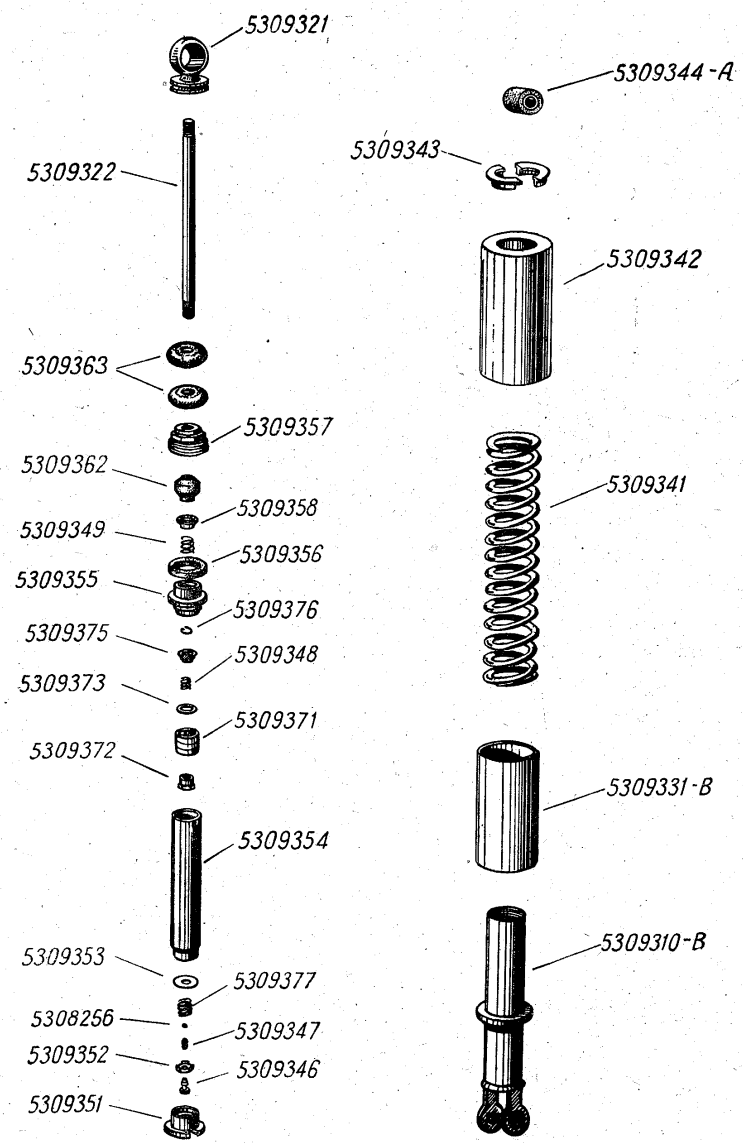

Fig. 20. Frame shock absorber.

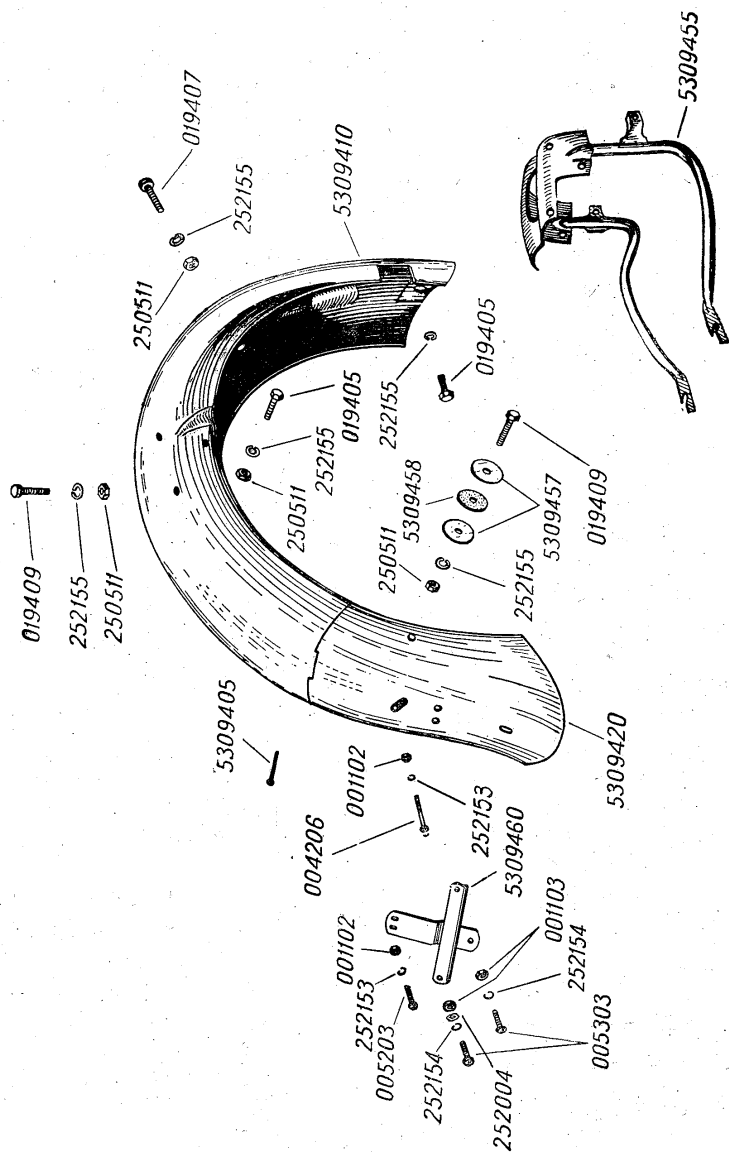

Fig. 21. Rear wheel mudguard.

Continued

1	2	3	4	5
22	7210145	Gasket	6	B
22	7210147	Petrol tank fixing bolt washer	2	B
22	7210149	Petrol tank connecting tube	1	B
22	201264	Bolt fixing rear part of the petrol tank to the frame	2	
22	7210171-B	Petrol tank	1	B
22	252155	Spring washer for the bolt fixing the front part of the petrol tank to the frame	2	
22	019405	Bolt fixing the front part of the petrol tank to the frame	2	
22	7210173-B	Tool box cover, assembled	1	B
22	7210183-A	Tool box lock key	1	B
22	011407	Fuel cock plug thickening washer	1	
22	7210321	Right-hand carburetter fuel pipe	1	B
22	7210324	Left-hand carburetter fuel pipe	1	B
22	7210408-A	Filler cap filter, assembled	1	B
22	72H10412	Petrol tank filler cap thickening washer	1	B
22	7210419	Petrol tank filler cap, assembled	1	B
GROUP 7211				
HANDLEBAR				
	72111-1	Handlebar, assembled	1	
23	7211101	Handlebar tube	1	B
23	019412	Handlebar bracket pinch bolt	2	
23	250511	Handlebar bracket pinch bolt nut	2	
23	252155	Handlebar bracket pinch bolt spring washer	2	
23	250513	Handlebar bracket nut	2	
23	252156	Handlebar bracket spring washer	2	
	72111-2	Throttle twist grip, assembled (assembly includes parts 72111-3, 7211109, 7211112-A, 7211113, 7211117, 7211118, 7211120, 7211121, 7211122, 7211327, 7211333, 264072)	1	B
23	72111-3	Throttle valve cable housing with cover	1	B
23	7211109	Throttle twist grip	1	B
24	7211112-A	Two cables connecting sleeve	2	B

1	2	3	4	5
24	7211113	Three cables connecting sleeve	3	B
24	7211115	Protective tube	1	B
23	264072	Throttle twist grip lubricator	1	
23	7211117	Slide block	1	B
23	7211118	Body fixing screw	1	B
	7211120	Upper connecting sleeve	2	B
23	7211121	Stop screw	2	B
23	7211122	Right-hand handlebar grip	1	B
23	7211123	Left-hand handlebar grip	1	B
23	7211124	Block screw	2	B
23	7211126	Block	2	B
23	7211127-A	Right-hand lever bracket	1	B
23	7211128-A	Left-hand lever bracket	1	B
23	7211129	Lever	2	B
23	7211131	Lever axle	2	B
23	001102	Lever axle nut	2	
24	7211132	Cable connecting sleeve	2	B
24	7211135	Protective connecting sleeve for cable	1	B
23	72H11902	Handlebar bracket	2	
Cables and cable sheaths				
24	5311206	Front brake cable clamp	1	
24	7211305	End stop cap	10	B
24	7211315	End stop pin	2	
24	7211310	End stop pin	1	B
24	7211320	Stop ring	2	
24	7211313-A	Clutch control cable sheath	1	B
	7211314-A	Clutch control cable sheath, assembled (assembly includes parts 7211132, 7211305, 7211313-A)	1	B
24	7211316	Clutch control cable	1	B
24	7211318-B	Adjusting screw	1	
24	250511	Clutch adjusting screw nut	1	
	7211319-A	Clutch control cable, assembled (assembly includes parts 7211310, 7211314-A, 7211315, 7211316, 7211318-B, 7211320, 250511)	1	
24	7211321-A	Throttle valve cable sheath	2	
24	7211322	Throttle valve cable	2	
24	7211323	Throttle valve cable upper end stop pin	2	B

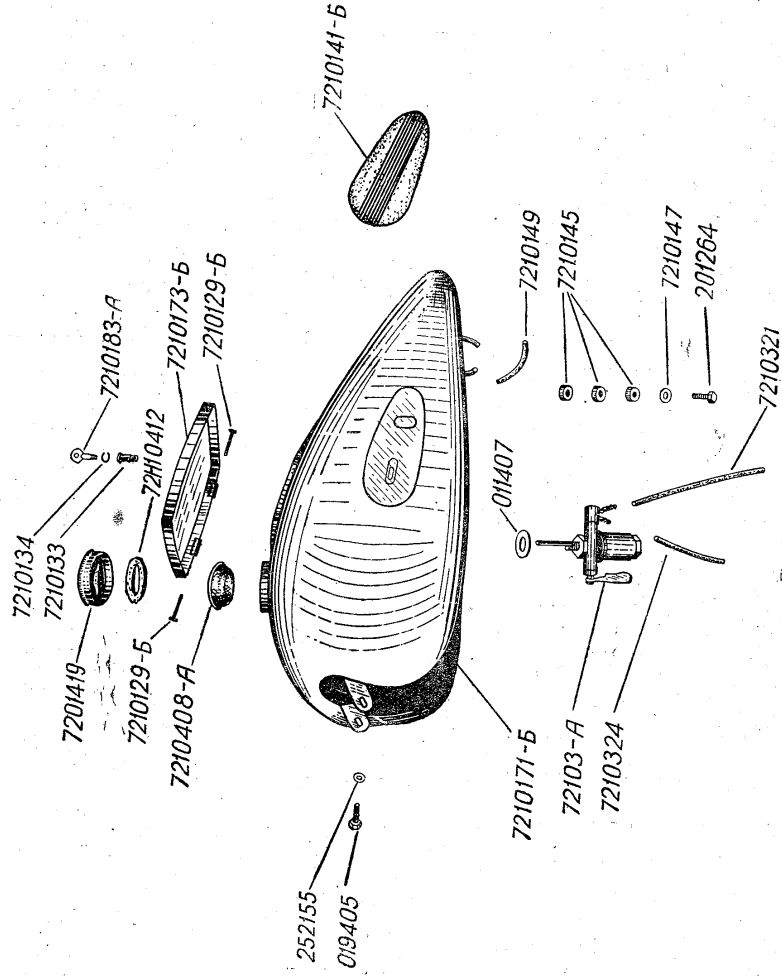

Fig. 22. Fuel tank.

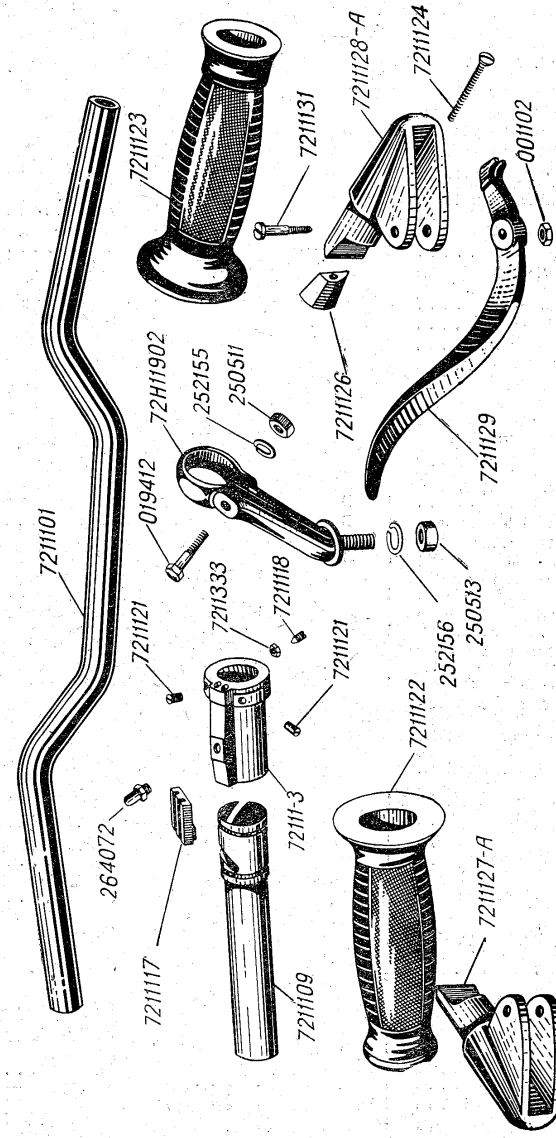
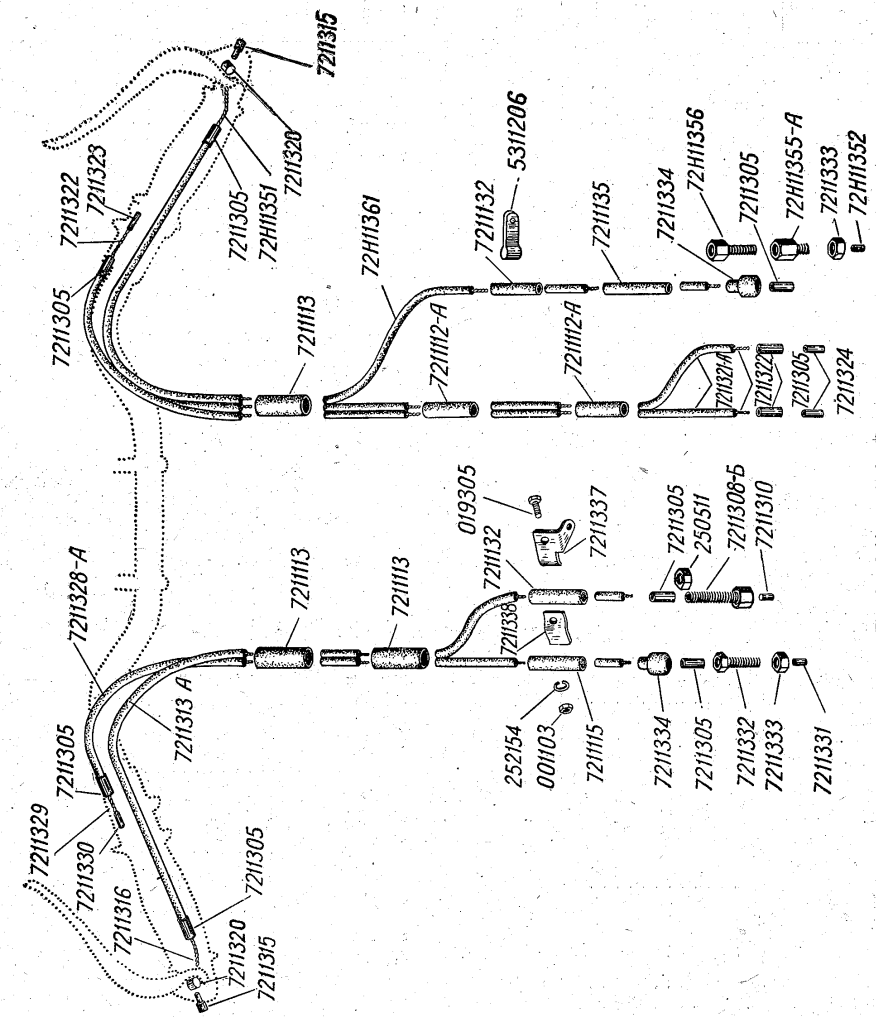

Fig. 23. Handlebar, control handles and levers.

Continued

1	2	3	4	5
24	7211324	Throttle valve cable lower end stop pin . . .	2	B
	7211327	Throttle valve cable, assembled (assembly includes parts 7211305, 7211321-A, 7211322, 7211323, 7211324) . . .	2	B
24	7211328-A	Ignition advance cable sheath	1	B
24	7211329	Ignition advance cable	1	B
24	7211330	Ignition advance cable end stop pin	1	B
24	7211331	End stop pin	1	B
24	7211332	Adjusting bolt	1	B
24	7211333	Nut	3	B
24	7211334	Protective sleeve	2	B
	7211336	Ignition advance cable, assembled (assembly includes parts 7211305, 7211328-A, 7211329, 7211330, 7211331, 7211332, 7211333, 7211334)	1	B
24	7211337	Cable fixing bracket	1	B
24	7211338	Clutch control cable fixing bracket cover plate	1	B
24	019305	Bracket bolt fixing the clutch control cable	1	
24	001103	Clutch control cable bracket bolt nut	1	
24	252154	Bolt spring washer for the bracket fixing the clutch control cable	1	
	72H11350	Front brake cable, assembled (assembly includes parts 7211315, 7211320, 7211333, 7211334, 7211351, 72H11352, 72H11355, 72H11356, 72H11360)	1	
24	72H11351	Front brake cable	1	
24	72H11352	Stop pin	1	
24	72H11355-A	Adjusting nipple	1	
24	72H11356	Adjusting screw	1	
	72H11360	Cable sheath, assembled (assembly includes parts 7211132, 7211135, 7211305, 72H11361)	1	
24	72H11361	Cable sheath	1	
	72H11500	Rear brake drive	1	
25	7211414-B	Rear brake arm spring	1	B
25	72H11440	Rear brake pedal with axle, assembled	1	
25	72H11504	Rear brake rod	1	
25	72H11507	Special arm pin	1	
25	72H11508	Special nut M6 x 1	1	

1	2	3	4	5
25	72H11540-A	Rear brake arm	1	
25	72H11543	Arm axle	1	
25	72H11551	Protective sleeve	1	
25	72H11552	Rear brake rod fork	1	
25	001103	Nut for fixing fork on rod	1	
25	250613	Rear brake arm axle nut	1	
25	252156	Axle spring washer for rear brake arm	1	
25	252005	Rear brake arm pin rough washer	1	
25	258013	Rear brake arm pin split cotter	1	
		GROUP 72H12		
		EXHAUST PIPES WITH SILENCERS		
	72H12	Exhaust pipes with silencers (assembly includes parts 7212103-B, 72H12104, 72H12107, 72H12108, 72H12225, 72H122)	1	
		Exhaust pipes		
26	7212103-B	Exhaust pipe fixing clip	2	B
26	72H12104	Right-hand cylinder exhaust pipe, assembled	1	
26	72H12107	Left-hand cylinder exhaust pipe, assembled	1	
26	72H12108	Connecting tube	1	
		Silencers		
26	72H12225	Silencer clip	2	
26	72H122	Silencer, assembled	2	
		GROUP 5313		
		FRONT SADDLE		
	5313	Driver's saddle, assembled	1	
27	201532	Driver's saddle fixing bolt	1	
27	250513	Driver's saddle to frame fixing nut	1	
27	252156	Driver's saddle fixing bolt spring washer	2	
	5313200	Saddle-tree with saddle yoke and cover, assembled (assembly includes parts 7213101-A, 5313203-A, 5313205, 5313230)	1	
27	7213101-A	Saddle cover	1	B
27	5313203-A	Bail	1	
27	5313205	Saddle-tree, assembled	1	



Continued

1	2	3	4	5
27	5313215	Reinforced rubber spring	1	
27	019405	Bolt fixing the saddle-tree to rubber spring	2	
27	252155	Spring washer for the bolt fixing the saddle-tree to the rubber spring	2	
27	201492	Bolt fixing the saddle rubber spring to the frame	1	

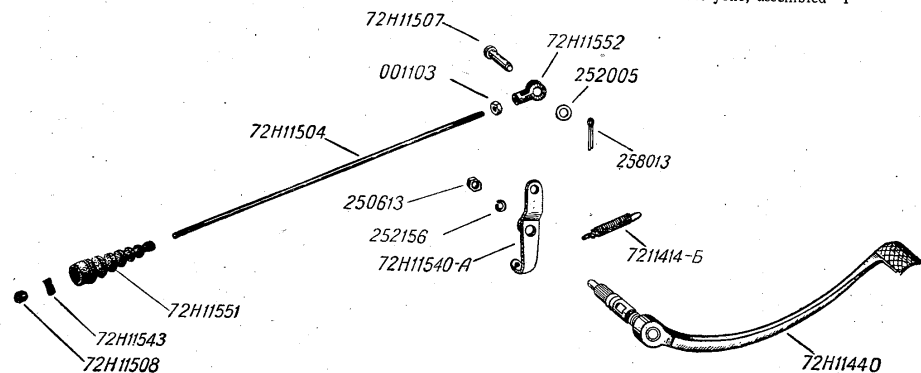

Fig. 25. Rear brake actuator.

27	5313230	Saddle yoke, assembled	1	
27	5313236	Reinforced rubber silent block	1	
27	5313241	Special square washer	2	
27	5313243	Special square washer	1	

GROUP 5314				
REAR SADDLE, ASSEMBLED				
5314		Rear saddle, assembled		
5313200		Saddle-tree with saddle yoke and cover, assembled (assembly includes parts 7213101 A, 5313203-A, 5313205, 5313230)	1	
28	5313203-A	Bail	1	
28	5313205	Saddle-tree, assembled	1	
28	5313215	Reinforced rubber spring	1	
28	019405	Bolt fixing the saddle-tree to rubber spring	2	

28	252155	Spring washer for the bolt fixing the saddle-tree to rubber spring	2	
28	201492	Bolt for fixing saddle rubber spring to bracket	1	
28	252156	Spring washer for the bolt fixing the saddle rubber spring to saddle pillar	1	
28	5313230	Saddle yoke, assembled	1	

28	5313236	Reinforced silent block	1	
28	5313241	Special square washer	2	
28	5313243	Special square washer	1	
28	5314500	Saddle pillar, assembled	1	
28	201532	Rear saddle fixing bolt	1	
28	252156	Spring washer for the bolt fixing the saddle to the pillar	1	
28	250513	Nut for the bolt fixing the rear saddle to the pillar	1	
28	5314510	Saddle handle	1	
28	019422	Saddle handle fixing bolt	1	
28	250511	Saddle handle fixing bolt nut	1	
28	252155	Saddle handle fixing bolt spring washer	1	
28	5314517	Gasket	1	
28	7213101-A	Saddle cover	1	B

Continued

1	2	3	4	5
GROUP 7215				
CARBURETTERS, CORRECTOR, AIR CLEANER				
29	7215-1	Right-hand carburetter, assembled	1	B
29	7215-2	Left-hand carburetter, assembled	1	B

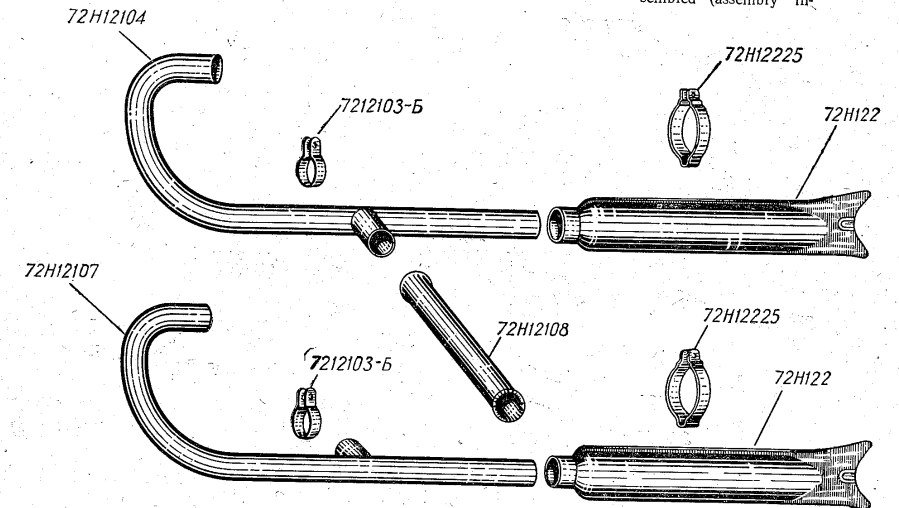

Fig. 26. Exhaust pipes with silencers.

Corrector				
7215-7A		Air corrector, assembled (assembly includes parts 7215-5, 7215203, 7215204, 7215251, 7215258-B, 7215259-A)	1	B
7215-5		Clip for fixing the packing cup of air pipe with screw (assembly includes parts 7215214-A, 223046, 001102)	2	B
29	7215203	Air pipe thickening ring	2	B
29	7215204	Air pipe packing cup	2	B
29	7215214-A	Air pipe packing cup fixing clamp	2	
29	223046	Screw for fixing the clip of packing cup	2	

29	001102	Nut for the screw fixing the clip of packing cup	2	
29	7215218	Protective cap for model K-37 carburetter	2	B
7215251		Air corrector tube, assembled (assembly in-		

29	7215253	Air corrector inner tube	1	B
29	7215254	Air corrector handle fixing bolt	1	B
29	7215256	Air corrector handle washer	1	B
29	7215257	Air corrector handle fixing bolt	1	B
29	001102	Air corrector handle fixing bolt nut	1	
29	252153	Air corrector handle fixing bolt spring washer	1	
29	252003	Air corrector handle fixing bolt rough washer	1	
29	7215258-B	Left-hand cylinder air pipe	1	B
29	7215259-A	Right-hand cylinder air pipe	1	B

Continued

1	2	3	4	5
---	---	---	---	---

Air cleaner

7215-6 Air cleaner, assembled
(assembly includes parts
7215208, 7215229,
7215234, 7215237,

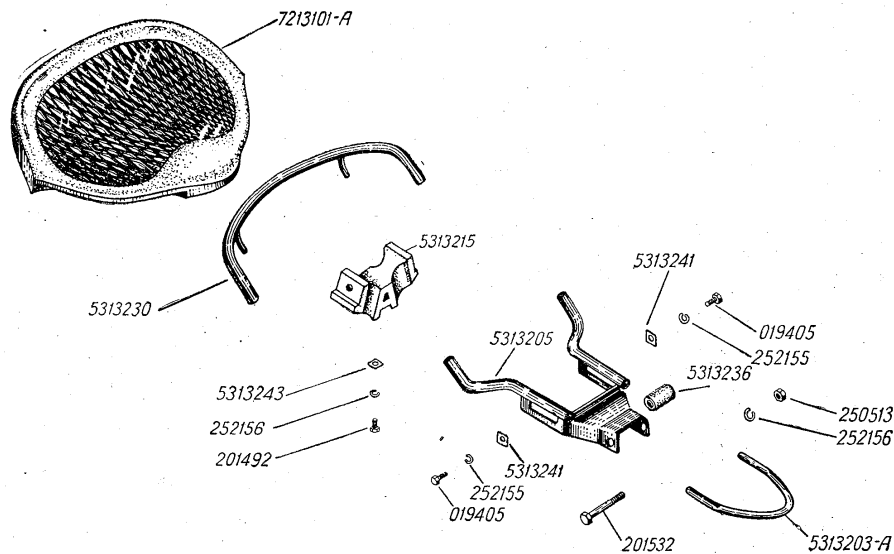

Fig. 27. Front saddle.

1	2	3	4	5
---	---	---	---	---

GROUP 75017/18

ELECTRICAL EQUIPMENT

Electric ignition devices, parts and their fastenings

30 72171-B Ignition coil B2-B . . . 1 B
30 019305 Ignition coil fixing
bolt 2

	7215238, 7215239, 7215240)	1	B	30	001103	Ignition coil fixing nut	2
29	7215208	2	B	30	252154	Ignition coil fastening spring washer	2
29	7215229	1	B	30	72172	Ignition distributor P1M05	1 B
29	7215234	1	B	30	72H173 7218817-B	Spark plug A8Y	2
29	7215237	1	B			High voltage cable from spark coil to distributor, assembled (assembly includes parts 7218802, 7218806, 7218815-B)	1 B
29	7215238	1	B	30	7218802	Wire terminal cap	3 B
29	7215240	1	B	30	7218806	Wire connector	4 B
29	7215242	2		30	5318811	Spark plug connector with damping resistance	2

50

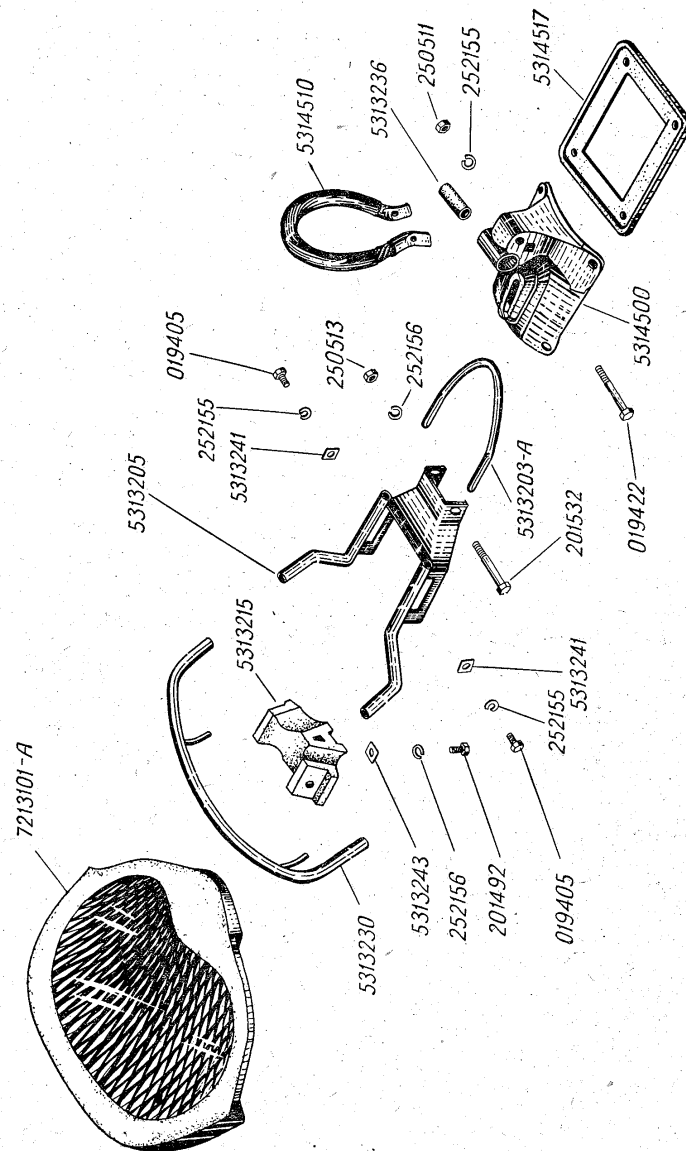

Fig. 28. Rear saddle.

4*

51

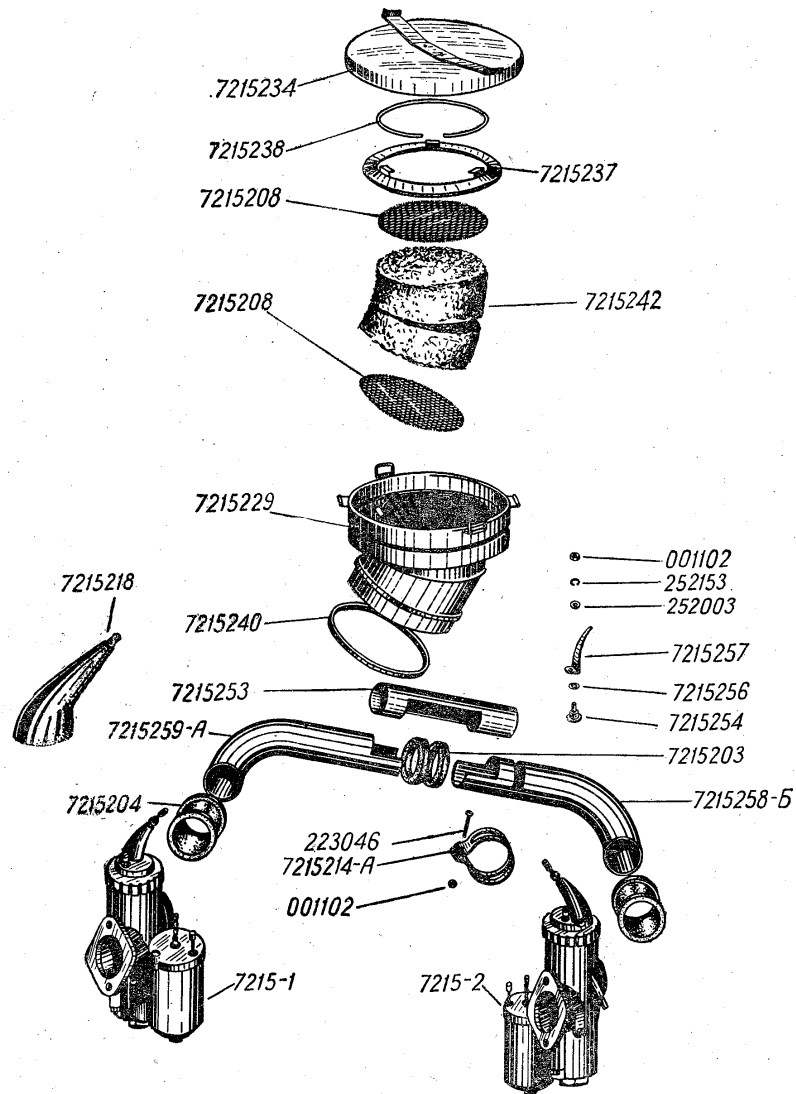

Fig. 29. Carburetters corrector and air cleaner.

Continued

1	2	3	4	5	1	2	3	4	5
30	7218812	High voltage wire to spark plugs	2	B	30	72186-A3	C-37 horn motorcycle	1	B
30	7218815-B	High voltage wire from ignition coil to distributor	1	B	30	019405	Horn fixing bolt	1	
		Electrical equipment devices and their fastenings			30	252155	Horn fixing spring washer	1	
30	72181-A	Generator Г-011-A	1	B	30	53187-B	ФП66 tail lamp	1	
30	72183-A1	Relay and volt regulator PP-31-A	1	B	30	5318715-A	Tail lamp gasket	1	
30	7218301	Relay and volt regulator gasket	1	B	30	7218801	Headlamp bushing	1	B
30	7218302	Relay to frame connector plate	1	B	30	72189-B	3MTM-14 motorcycle storage battery	1	B
30	019205	Relay and volt regulator fixing bolt	2		30	5318900-B ¹	Stop-signal pickup, assembled	1	
30	252153	Spring washer for the bolt fixing relay and volt regulator	2			250613	Stop-signal pickup fixing nut	1	
30	72184	Headlamp with speedometer and cables assembled (assembly includes parts 72174-A, 7217401, 72175-A1, 72176-B, 72177-B, 72184-1, 7218405-A, 7218414, 7218415, 7218416, 7218417, 7218418, 7218471, 72H188-5B, 72H188-6B, 7218801, 001102, 252153)	1	B	30	5318931	Bulb A18, 6 V, 6 W GOCT 2023-50	1	
					30	5318933	Bulb A17, 6 V, 3 W GOCT 2023-50	1	
							Electrical wires and their Fastenings		
30	72174-A	Speedometer ЦП-85	1	B	30	72188-3	Wire from ignition coil to contact braker	1	B
30	7217401	Speedometer fixing bracket	2	B	30	72188-4	Battery to frame lead	1	B
30	72175-A1	Flexible shaft ГВ-1	1	B	30	72H188-5B	Ignition coil, horn and sidcar bunch of cables	1	
30	72176-B	Bulb A42, 6 V, 32 + 21 W	1	B	30	72H188-6B	Bunch of leads to generator, stop-light, relay regulator, storage battery and tail lamp	1	
30	72177-B	Bulb A19, 6 V 2 W GOCT 2023-50	1	B		7218803 ²	Cable coupling	1	B
	72184-1	Headlamp with bulbs, assembled	1	B		7218804 ³	Terminals insulating cap	12	B
30	7218414	Speedometer thickening ring	1	B		72H18831 ⁴	Cable coupling	2	
30	001102	Speedometer fixing nut	2			7218415	Wire from main switch to parking light	1	B
30	252153	Speedometer fastening spring washer	2			7218416	Wire from main switch to control switch	1	B
30	7218419	Headlamp fixing bolt sleeve	2	B		7218417	Wire from light control switch to headlamp central bulb (city light)	1	B
30	7218469	Thickening washer for bolt washer	4	B		7218418	Wire from light control switch to headlamp central bulb (country light)	1	B
30	7218935	Bulb A19, 6 V, 2 W GOCT 2023-50	1	B		7218471	Headlamp cables tube	4	B
30	7218936	Control bulb A35, 6V, 15 W	1	B	30	65018820	Tail lights cable connector	1	B
30	7218405-A	Light control switch cable sheath	1	B		366301	Screw fastening the cables in connector	2	
30	72185	Spark advance, horn and light control switch combined lever	1	B	30	7218818	Cable holder lock	7	B

¹ Stop-signal pickup for motorcycle type ИЖ-56 is temporarily installed instead of part 5318900-B
² Included in bunch 72H188-5B
³ Included in bunches 72H188-3, 72H188-4, 72H188-5B, 72H188-6B, 72H188-9
⁴ Included in bunches 72H188-6B, 72H188-8.

Continued

1	2	3	4	5	1	2	3	4	5
33	201418	Pump fixing clip bolt	4		33	019412	Bolt to fix front part of sidecar body	4	
33	001103	Pump fixing clip nut	4		33	250511	Nut to fix front part of sidecar body	8	
33	252154	Pump fixing clip spring washer	4		33	252155	Spring washer for front part of sidecar body fastening	8	
33	65021-2	Stop pin, assembled	1						
33	65021005	Buffer	2						

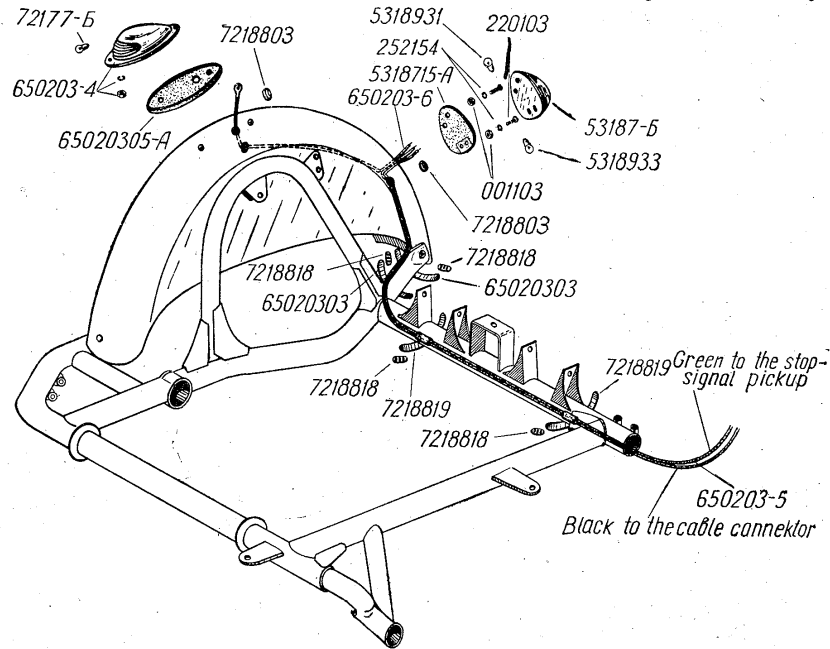

Fig. 32. Wiring diagram of sidecar electrical equipment.

33	252156	Spring washer for shock absorber to sidecar body fastening	2	33	252005	Rough washer for front part of sidecar body fastening	8
33	250513	Stop pin nut	3	33	009509	Body fixing pin	2
33	250613	Stop pin nut	1	33	65021158	Sidecar body fastening washer	2
33	65021006	Sidecar body suspension pad clamp	2				
33	65021008	Sidecar body suspension pad	4				
33	201476	Bolt to fix front part of sidecar body	4				
				7224-1A	Tool kit	1	
				72H24-6A	Kit for spares	1	

58

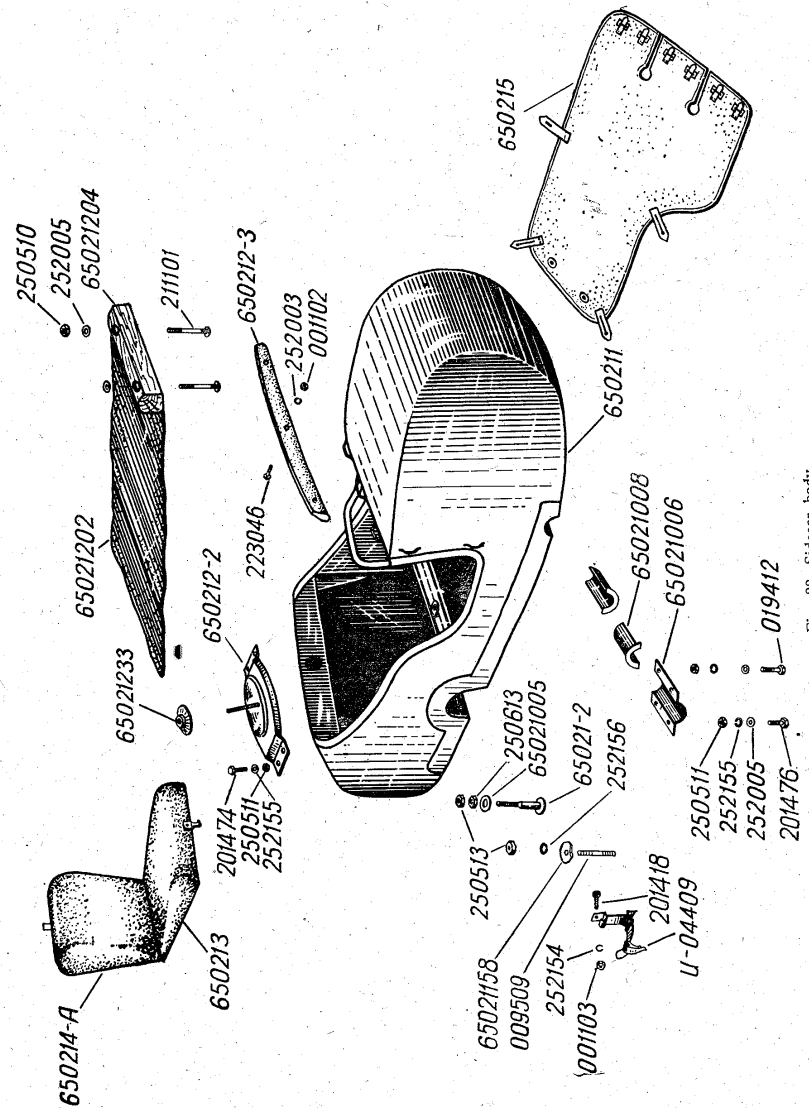

Fig. 33. Sidecar body.

59

Continued

1	2	3	4	5	1	2	3	4	5
34	7224-7	Tyre repair kit . . .	1	B	34	7224116-B	Box spanner 10 × 14	1	B
34	7224-9	Hammer with handle	1	B]	34	7224118-B	Box spanner 11 × 12	1	B
34	7224008	Air pump	1	B	34	7224121-A	Box spanner 19 × 22	1	B
34	7224009	Generator repair kit .	1	B	34	7224122	Tap wrench	1	B
34	7224010A2	Tyre gauge	1	B	34	7224153	Wrench 9 × 11	1	B
34	7224016A	Feeler gauge, assembled	1	B	34	7224125	Screw driver (motor-cycle type) 150	1	B
34	7224103A	Pliers	1	B		7224127-A	Tool bag	1	
34	7224105	Screw driver	1	B	34	7224142-B	Grease gun	1	B
34	7224106	Box spanner 14	1	B	34	7224143	Shovel (motorcar type)	2	B
34	7224107	Wrench for carburetter eccentric regulation, assembled	1	B	34	7224171	Double-ended wrench 8 × 10	1	B
34	7224111	Needle file	1	B	34	7224172	Wrench 12 × 14	1	B
34	7224114	Double-ended spanner 36 × 41	1	B	34	7224173	Wrench 14 × 17	1	B
34	7224115	Hub lock nut hook spanner	1	B	34	7224174	Wrench 19 × 22	1	B
					34	72H24957	Double-ended spanner, assembled	1	

PART II

FITTINGS SUPPLIED BY OTHER MANUFACTURERS

ELECTRICAL EQUIPMENT AND DEVICES

Part number by contractor works catalogue	Part number by motorcycle manufacturing works catalogue	Description	Q'ty per motorcycle	Part number by contractor works catalogue	Part number by motorcycle manufacturing works catalogue	Description	Q'ty per motorcycle
B2-B	72171-B	Ignition coil	1	П-45	72185	Spark advance lever, combined	1
ПМ05	72172	Distributor	1	C-37	72186-A3	Small-sized horn . . .	1
A8V	72H173	Spark plug	2	3МТМ-14	72189-B	Storage battery	1
СП-8Б	72174-A	Speedometer (motor-cycle type)	1	ФП66	53187-B	ФП66 tail lamp for motorcycle	2
ГВ-1	72175-A1	Flexible shaft	1	С9-13	5318811	Plug cap with damping resistance . .	1
A42	72176-B	Bulb A42, 6 V, 32+21 W	1	A18	6318931	Bulb A18, 6 V, 6 W . .	2
A19	72177-B	Bulb A19 or A16, 6 V, 1-2 W	2	A17	5318933	Bulb A17, 6 V, 3 W . .	2
Г11-A	72181-A	Generator	1	A19	5318935	Bulb of brightening A19, 6 V, 2 W . .	1
PP31-A	72183-A1	Relay and volt regulator	1	A35	5318936	Control lamp A35, 6V .	1
ФГ-6А	72184-1	Headlamp	1	M72-B	650203-4	Sidecar headlamp . . .	1
					5318900-B	Stop-signal pickup . .	1

CABLES

Number of bunch or cable	Description	Group	Q'ty per motorcycle	Main data		
				cable mark	cross section, mm ²	length, mm
1	2	3	4	5	6	7
7218415	Cable from main switch to city light bulb	72184	1	АОЛ ГОСТ 974-47	1.5	320

Continued

1	2	3	4	5	6	7
7218416	Cable from main switch to light control switch	72184	1	АОЛ ГОСТ 974-47	1.5	320
7218417	Cable from light control switch to headlamp (city light)	72184	1	АОЛ ГОСТ 974-47	1.5	170
7218418	Cable from light control switch to headlamp (country light)	72184	1	АОЛ ГОСТ 974-47	1.5	170
72188-3	Cable from ignition coil to contact breaker	75001	1	АОЛ ГОСТ 974-47	1.5	210
72188-4	Ground cable	K-750	1	АОЛ ГОСТ 974-47	1.5	300
72H188-5B	Bunch of cables to ignition coil, horn and sidecar	72184	1	АОЛ ГОСТ 974-47	1.5	950 870 430
72H188-6B	Bunch of cables to generator, stop-signal, relay and volt regulator, storage battery and tail lamp	72184	1	АОЛ ГОСТ 974-47	1.5	260 680 680 1020 1360 1610 1340
72H188-8	Bunch of cables to stop-signal and tail lamp	K-750	1	АОЛ ГОСТ 974-47	1	1270 1050
72H188-9	Cable from button to horn	K-750	1	АОЛ ГОСТ 974-47	1.5	720
7218812	High tension cable to spark plug	75001	2	ПВЛ-1 ГОСТ 3923-47	—	440
7218815-B	High tension cable from ignition coil to distributor	7218817-B	1	ПВЛ-1 ГОСТ 3923-47	—	270
650203-5	Cross of sidecar cables	650203	1	АОЛ ГОСТ 974-47	1	2100 1950
650203-6	Cable to sidecar side lamp	650203	1	АОЛ ГОСТ 974-47	1	840

BEARINGS

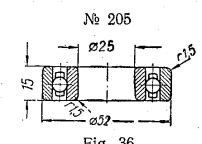
Number of bearing		Type	Designation and place of installation	Qty per motor cycle
according to contractor works specifications	according to USSR Standards			
1	2	3	4	5
 <p>№ 205 Fig. 36</p>	205 ГОСТ 8338-57	Single-row radial ball bearing	Ball bearing of camshaft; installed on camshaft	1
			Ball bearing of primary shaft of gearbox; installed on primary shaft	1

Continued

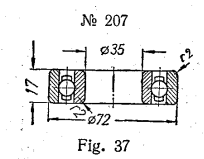
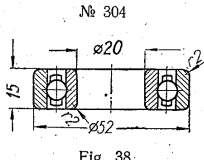
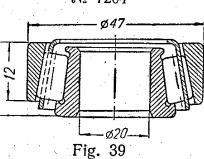
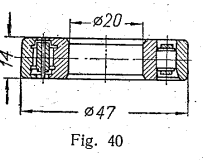
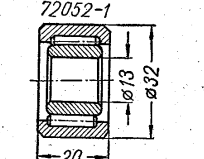
1	2	3	4	5
 <p>№ 207 Fig. 37</p>	207 ГОСТ 8338-57	Single-row radial ball bearing	Front ball bearing for crank gear; installed in the housing of front bearing	1
			Rear ball bearing for crank gear; installed in housing of rear bearing	1
			Main gear ball bearing driven pinion; installed in gear hub and housing cover	1
 <p>№ 304 Fig. 38</p>	304 ГОСТ 8338-57	— do —	Secondary shaft ball bearing; installed in front cover of gearbox crankcase	2
 <p>№ 7204 Fig. 39</p>	7204 ГОСТ 333-55	Single-row conical bearing	Wheel roller bearing; installed in wheel hub	8
 <p>№ 2H12204 Fig. 40</p>	2H12204 ГОСТ 8328-57	Radial roller bearing with short cylindrical rollers	Roller bearing for primary shaft of gearbox; installed in gearbox crankcase and on gearbox primary shaft	1
 <p>№ 874901 72052-1 Fig. 41</p>	874901	Needle bearing	Rear drive driving gear bearing; installed in rear drive crankcase and on rear drive driving gear	1

Continued

1	2	3	4	5
<p>№ 3086304JI 72052-2</p> <p>Fig. 42</p>	3086304JI	Double-row radial thrust ball bearing	Ball bearing; installed on rear drive gear and into the gearbox	1
<p>№ 778707 72081-2</p> <p>Fig. 43</p>	778707	Radial thrust ball bearing	Ball bearing with racers; installed in steering column and on steering column rod of front fork	2
<p>№ 822907 7201208, 7201209</p> <p>Fig. 44</p>	822907	Radial roller bearing with short cylindrical rollers without racers	Cage. Roller. Installed in crank gear	2
<p>№ 904700 72053-2</p> <p>Fig. 45</p>	904700	Needle bearing	Cardan pivot bearing; installed on trunnion	4
<p>№ 948066 7203209</p> <p>Fig. 46</p>	948066	Thrust ball bearing without racers	Thrust ball bearing without racers; installed in gearbox for clutch gear shift unit	1

Continued

1	2	3	4	5
<p>5308108</p> <p>Fig. 47</p>	FOCT 6870-54	Needle roller	Front fork lever roller; installed in front fork housing	120
RUBBER SEALS				
<p>Fig. 48. Type A seal</p>	<p>Fig. 49. Type B seal</p>	<p>Fig. 50. Type B seal</p>		

Number	Description	Group	Q'ty per motor-cycle	Type	Specification, No.	Main data		
						Dimensions, mm		
						D	d	H
7201122-B	Camshaft oil seal cup	75001	1	A	204-54p 3544-52	30	15	7
7204122-A	Oil seal for shaft of starting mechanism	7204	1	B	204-54p 3544-52	53	19	8
7204147	Cup for oil seal of gearbox crankcase right-hand cover	7204	1	A	204-54p 3544-52	25	11	5
7204152	Primary cup shaft oil seal	7204	1	A	204-54p 3544-52	45	31	7
7204157	Secondary shaft oil seal	7204	1	A	204-54p 3544-52	48	35.5	8
7205113-A	Rear drive crankcase gland flange	72H05	1	B	204-54p 3544-52	93	44	11
7205334	Cardan yoke oil seal cup	72H05	1	A	204-54p 3544-52	40.3	33	8
5306127	Oil seal cup	5306	4	A	204-54p	38	24	8
5306215	Front brake disk gland	5306	1	B	233-54p	56	46	5
5308129-A	Oil seal	5308	2	B	233-54p	35	23.5	5.5
5308159	Steering column lower gland	5308	1	B	233-54p	58	51	3.5

RUBBER TUBES

Number	Description of tubes	Group	Q'ty per motor-cycle	Specifications No.	Diameter, mm		Length, mm
					inner	outer	
7210149	Petrol tank connecting tube	7210	1	1619-50	6	12.5	130
7210321	Left-hand carburetter fuel pipe	7210	1	1619-50	6	12.5	285
7210324	Right-hand carburetter fuel pipe	7210	1	1619-50	6	12.5	175

RUBBER PARTS

Part number	Description	Group	Q'ty per motorcycle	Rubber type and specification No.
1	2	3	4	5
7201105	Spacing tube packing ring	75001	2	gr. IV6 TY 233-54p
7201163	Generator gasket	75001	1	gr. IV6 TY 233-54p
7203207	Clutch release slide ring	7203	1	gr. IV6 TY 233-54p
72H04422	Sleeve for pedal of starting mechanism lever	7204	1	gr. I, TY 204-54p
7205306-B	Cardan shaft packing ring	72H05	1	gr. IV6 TY 233-54p
7205312	Cardan packing ring	72H05	4	gr. IVa TY 233-54p
7205324-B	Elastic cardan coupling	72H05	1	mixture 93 TY 233-54p
5306240	Pin with bushing, assembled	72H06	2	gr. IV6 TY 204-54p
7206123	Flipper for 19 in. rim	72H06	4	GOCT 5652-51
7206124	Inner tube for motorcycle 3.75-19 tyre	72H06	4	GOCT 5652-51
7206126	Motorcycle 3.75-19 tyre	72H06	4	GOCT 5652-51
5308107	Bumper	5308	2	gr. Vb TY 233-54p
5308108	Compressing bumper	5308	2	gr. IVb TY 204-54p
5308194	Headlamp bracket packing ring	5308	2	gr. I6 TY 233-54p
7209168-B	Storage battery gasket	5309	1	gr. I6 TY 233-54p
5309182	Passenger's footrest fillet	5309	2	gr. Ib TY 233-54p
7209186	Footrest long cushion	5309	1	gr. I6 TY 233-54p
7209187	Footrest short cushion	5309	1	gr. I6 TY 233-54p
5309259	Silent block bushing	5309	8	gr. VIb TY 204-54p
7209301	Footrest fillet	5309	2	gr. Ib TY 233-54p
5309344-A	Distance bushing with rubber	5309	6	gr. XIV6 TY 204-54p
5309356	Packing ring	5309	3	gr. IV6 TY 233-54p
5309362	Oil seal	5309	3	gr. XIX6 TY 204-54p
5309363	Compressing bumper	5309	6	gr. XIV6 TY 204-54p
5309458	Bolt washer gasket	5309	2	gr. Ib TY 233-54p
7210141-B	Knee grip	7210	2	gr. IV6 TY 233-54p
7210145	Gasket	7210	4	gr. IVb TY 233-54p
7211112-A	Two cables junction sleeve	7211	2	GOCT 5496-50
7211113	Three cables junction sleeve	7211	3	GOCT 5496-50
7211115	Protecting tube	7211	1	GOCT 5496-50
7211120	Upper junction sleeve	7211	2	GOCT 5496-50
7211122	Handle-bar right-hand grip	7211	1	gr. IVb TY 233-54p
7211123	Handle-bar left-hand grip	7211	1	gr. IVb TY 233-54p
7211132	Front brake cable sleeve	7211	2	GOCT 5496-50
7211135	Protecting cable sleeve	7211	1	GOCT 5496-50
7211334	Protecting sleeve	7211	2	gr. I6 TY 233-54p
72H11551	Protecting sleeve	7211	1	gr. IVa TY 233-54p
7213101-A	Saddle cover	5313, 5314	2	mixture C491
5313215	Saddle spring with reinforcement	5313, 5314, 65020	4	gr. VI6 TY 204-54p
5313236	Silent block	5313, 5314	2	gr. VIb TY 204-54p
7214329	Handle tube	5314	1	gr. XIIF TY 204-54p
5314517	Gasket	5314	1	gr. I6 TY 233-54p
7215203	Air pipe packing ring	7215	2	gr. IV6 TY 233-54p
7215204	Air pipe packing sleeve	7215	2	gr. IVb TY 233-54p
7215218	K-37 carburettor protective cap	7215	2	gr. IV6 TY 233-54p
7218301	Relay and volt regulator gasket	75018	1	gr. I6 TY 233-54p
7218414	Speedometer packing ring	75018	1	mixture N 240 TY 233-54p
7218419	Headlamp fixing bolt bushing	75018	2	gr. I6 TY 233-54p

Continued

1	2	3	4	5
721469	Bolt washer gasket	75018	4	gr. Ib TY 233-54p
7218471	Headlamp wires tube	75018	4	GOCT 5496-50
5318715-A	Tail lamp gasket	75018, 65020	2	gr. I6 TY 233-54p
7218801	Headlamp bushing	75018	1	gr. I6 TY 233-54p
7218802	Wire terminal cap	75018	3	gr. IVb TY 233-54p
7218803	Wire sleeve	75018, 65020	3	gr. I6 TY 233-54p
7218804	Terminal insulating cap	75018	12	gr. Ia TY 233-54p
7218806	Wire bushing	75018	4	gr. IV6 TY 233-54p
72H18831	Headlamp wire sleeve	75018	2	gr. I6 TY 233-54p
5318964 ¹	Protective cap	75018	1	gr. IVa TY 233-54p
65020105	Lever stop buffer	65020	2	gr. I6 TY 233-54p
65020305-A	Lamp gasket	65020	1	gr. I6 TY 233-54p
65021005	Bumper	65021	1	gr. IV TY 204-54p
65021008	Pad for sidecar body suspension from frame	65021	4	gr. I6 TY 233-54p
65021202	Sidecar rubber rug	65021	1	gr. XVI TY 204-54p

ASBESTOS PARTS

Part number	Description	Group	Q'ty per motorcycle	Specification No.	Thickness, mm
7203102	Friction lining for driven disk clutch	7203	4	325-H	3
5306251	Lining	72H06	4	325-H	5

CORK PARTS

Part number	Description	Group	Q'ty per motorcycle	Specification No.	Thickness, mm
7201159	Valve chamber cover gasket	75001	2	22-53	2.5
7201162	Oil pan gasket	75001	1	22-53	2.5
7201422	Valve spring gasket	75001	4	22-53	2.5
7205224	Rear drive bearing nut gasket	72H05	1	22-53	1.5
72H10412	Fuel tank plug gasket	7210	1	22-53	3

PAPER PARTS

Part number	Description	Group	Q'ty per motorcycle	Specification No.	Thickness, mm
1	2	3	4	5	6
7201161	Cam box cover gasket	75001	1	155-52	0.2 to 0.25
7201164	Rear bearing housing gasket	75001	1	155-52	0.2 to 0.25
7201303	Cylinder gasket	75001	2	155-52	0.2 to 0.25
7201306	Carburettor thin gasket	75001	4	155-52	0.5 to 0.57
7201611	Oil pump housing gasket	75001	1	155-52	0.2 to 0.25
7204127	Gear box front cover gasket	7204	1	155-52	0.2 to 0.25
7204128	Gear box right-hand cover gasket	7204	1	155-52	0.2 to 0.25

¹ Cap 5318909, for stop-signal pickup of ИЖ-56 motorcycle

Continued

1	2	3	4	5	6
7204129	Gear box left-hand cover gasket . . .	7204	1	155-52	0.2 to 0.25
7204131	Gasket for front bushing of starting mechanism shaft	7204	1	155-52	0.2 to 0.25
7204132	Gasket for the cover of secondary shaft front bearing	7204	1	155-52	0.2 to 0.25
7204140	Gasket for rear bushing of starting mechanism shaft	7204	1	155-52	0.2 to 0.25
7204205	Primary shaft front bearing gasket . .	7204	1	155-52	0.2 to 0.25
7205107	Rear drive crankcase cover gasket . .	72H05	1	155-52	0.2 to 0.25
5308228	Gasket	5308	2	155-52	0.5

PARONITE PARTS

Part number	Description	Group	Q'ty per motorcycle	USSR standart No.	Thickness, mm
7201307	Carburetter thick gasket	75001	2	481-58	4

FELT PARTS

Part number	Description	Group	Q'ty per motorcycle	USSR standart No.	Thickness, mm
7201142	Crank oil seal	75001	1	288-53	5.5
7203213	Clutch engaging pin oil seal	7203	1	288-53	8
7204116	Oil seal collar	7204	1	288-53	4.5
7204142	Gear shifting pedal oil seal collar . .	7204; 72H05	3	288-53	4.5
7204144	Crankcase packing felt	7204	1	6418-52	12
5308156	Steering column upper oil seal	5308	1	6308-52	6
7215245	Packing gasket	7215	1	6308-52	4

PLASTIC PARTS

Part number	Description	Group	Q'ty per motorcycle
5308196-II	Fork tube plug	5308	2
5308300-II	Wing nut for handle-bar shock absorber, assembled . .	5308	1
7210417-A	Fuel tank plug, assembled	7210	1

UNITS PRODUCED BY CONTRACTOR WORKS

Unit number according to contractor works catalogue	Unit number according to motorcycle manufacturer catalogue	Description	Q'ty per motorcycle
KP-15A K37A n/c K37A n/c	7201217-A	Compression piston ring	2
	7201218-A	Oil control piston ring	4
	7201235	Upper chromium-plated compression ring	2
	72H06153	Wheel rim	4
	72103-A	Motorecycle fuel cock	1
	7215-1	Right-hand carburetter	1
	7215-2	Left-hand carburetter	1
	7224-7	Tyre repair kit	1
	7224008	Hand-operated air pump	1
	7224010-A	Tyre gauge	1
PH6-Г or PBH-1 MД3-A	7224016-A	Probe	1
	7224142-B	Grease gun	1
Ш16-A			

SPRINGS

Part number	Description	Group	Q'ty per motorcycle
7201419	Valve spring	75001	4
7203115	Clutch pressure spring	7203	6
7204329	Pressure spring for gear shifting unit	7204	1
7204414	Starting unit spring	7204	1

PART III
FASTENINGS

HEXAGONAL-HEADED BOLT (see Fig. 51)

Bolt number	Interchangeable with bolt	Main dimensions, mm					Q'ty per motorcycle	Group	Q'ty per group
		$d \times t$	l	l_0	h	S			
1	2	3	4	5	6	7	8	9	10
201472	019403	M8 × 1	12	12	5.5	12	8	72H05	8
201474	019405	M8 × 1	16	16	5.5	12	20	5308	2
								72H09	3
								7210	2
								5313	2
								5314	2
								75017/18	1
								65020	4
								65021	4
201476	019407	M8 × 1	20	20	5.5	12	7	72H09	1
								65020	2
								65021	4
201478	019409	M8 × 1	25	25	5.5	12	12	72H09	8
								65020	4
201264		M8 × 1	28	28	5.5	12	2	7210	2
200288	019412	M8 × 1	32	25	5.5	12	6	7211	2
								65020/21	4
201486		M8 × 1	45	25	6	12	1	65021	1
201489	019420	M8 × 1	55	25	5.5	12	1	75001	1
200298	019422	M8 × 1	65	25	5.5	12	1	5314	1
201526	019515-A	M10 × 1	45	30	7	14	8	72H09	4
								65020	4
201527		M10 × 1	48	30	7	14	2	65020	2
201531	019522	M10 × 1	65	30	7	14	4	5308	2
								72H09	2
201532		M10 × 1	70	30	7	14	2	5313	1
								5314	1
201562	019610	M12 × 1.25	28	28	8	17	1	72H09	1
201567	019615	M12 × 1.25	40	35	8	17	1	72H09	1

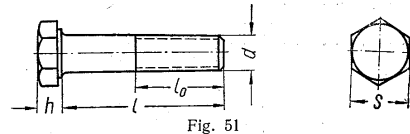

Fig. 51

Continued

1	2	3	4	5	6	7	8	9	10
201571		M12 × 1.25	50	35	8	17	2	65020	2
019205	220080	M5	16	16	3.5	8	2	75017/18	2
201418	019305	M6	16	16	5	10	25	75001	16
								72H05	1
								72H06	1
								7211	1
								75017/18	2
								65020/21	4
201420	019307	M6	20	20	5	10	12	5308	12
201422	019309	M6	25	20	5	10	11	7204	11
201428	019315	M6	40	20	5	10	1	7203	1
201432	019319	M6	50	20	5	10	2	75001	2
201455	018406	M8	18	18	6	12	2	75001	2
200274	018424	M8	75	25	6	12	1	75001	1
201492		M10	14	14	7	14	2	5313	1
								5314	1
201497	018509	M10	25	25	7	14	4	7 H09	2
								65020	2

HEXAGONAL-HEADED CLEVIS BOLT

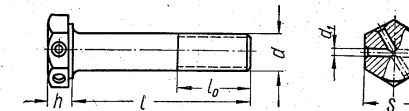

Fig. 52

Bolt number	Interchangeable with bolt	Main dimensions, mm					Q'ty per motorcycle	Group	Q'ty per group	
		$d \times t$	l	l_0	h	S				
206462	021305	M6	16	16	3.5	10	1.5	9	75001	9

HEXAGONAL-HEADED BOLT WITH AN OPENING IN ITS CORE

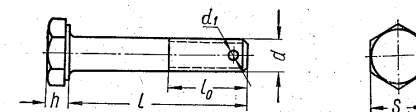

Fig. 53

Bolt number	Main dimensions, mm						Q'ty per motorcycle	Group	Q'ty per group
	$d \times t$	l	l_0	h	S	d_t			
365001	M12 × 1.25	42	22	9	17	3.5	4	65020	4

CUP-HEADED BOLT WITH SQUARE UNDERHEAD

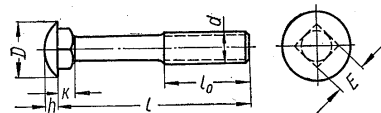

Fig. 54

Bolt number	Main dimensions, mm							Q'ty per motorcycle	Group	Q'ty per group
	$d \times t$	l	l_0	h	D	E	K			
211101	M8	55	25	4	20	8	5	2	65021	2

COUNTERSUNK-HEADED SCREW

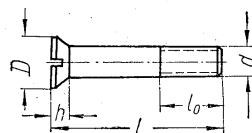

Fig. 55

Screw number	Interchangeable with screw	Main dimensions, mm					Q'ty per motorcycle	Group	Q'ty per group
		$d \times t$	l	l_0	h	D			
221578	003203	M5	12	9.5	2.5	10	4	75001	4
221580	003204	M5	16	13.5	2.5	10	2	7204	2
221605	003304	M6	16	13	3	12	15	75001	8
								7204	7
221611	003308	M6	30	27	3	12	6	75001	6
221617	003311	M6	45	30	3	12	4	75001	4

HALF-COUNTERSUNK-HEADED SCREW

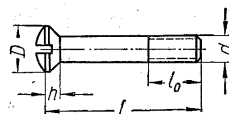

Fig. 56

Screw number	Interchangeable with screw	Main dimensions, mm					Q'ty per motorcycle	Group	Q'ty per group
		$d \times t$	l	l_0	h	D			
223043	004206	M5	22	19.5	2.5	10	5	7204	4
								72H09	1

Continued

1	2	3	4	5	6	7	8	9	10
223046	004208	M5	30	27.5	2.5	10	7	75001	2
								7215	2
								65021	3
223064	004304	M6	14	11	3	12	6	7204	6
223081	004314	M6	60	30	3	12	2	75001	2
223126		M8	25	21	4	16	1	72H05	1

CUP-HEADED SCREW

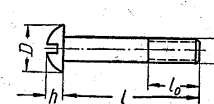

Fig. 57

Screw number	Interchangeable with screw	Main dimensions, mm					Q'ty per motorcycle	Group	Q'ty per group
		$d \times t$	l	l_0	h	D			
005100		M4	5	5	3	6.5	2	72H09	2
220078	005203	M5	12	12	3.6	9.5	13	75001	4
								72H05	7
								72H09	2
220088	005209	M5	35	35	3.6	9.5	1	72H09	1
220103	005303	M6	12	12	5.5	11.5	7	5303	1
								72H09	3
								65020	3
220104		M6	14	14	5.5	11.5	1	65020	1

BEVEL-POINTED SET SCREW

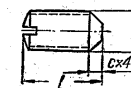

Fig. 58

Screw number	Main dimensions, mm			Number per motorcycle	Group	Number per group
	$d \times t$	l	c			
242221	M6	12	2	3	7204	3
366301	M4	4	0.7	2	75017/18	2

6*

POINTLESS SET SCREW

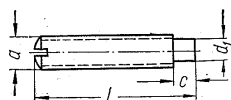

Fig. 59

PLUG

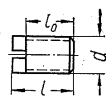

Fig. 60

Screw number	Main dimensions, mm				Q'ty per motorcycle	Group	Q'ty per group
	d x t	l	d ₁	c			
243219	M8 x 1	45	6	5	2	7204	1

Screw plug number	Main dimensions, mm			Q'ty per motorcycle	Group	Q'ty per group
	d x t	l	l ₀			
013102	M6	10	6	1	75001	1

STUD



Fig. 61

Stud number	Main dimensions, mm					Q'ty per motorcycle	Group	Q'ty per group
	d x t	l	l ₀	l ₁	d ₁			
009209	M5	30	12	12	M5	1	75001	1
009305	M6	18	12	15	M6	2	75001	2
009403	M8 x 1	13	12	9	M8	1	75001	1
008406-A	M8 x 1	21	15	15	M8	11	75001	2
							72H05	9
009407	M8 x 1	22	15	20	M8	4	75001	4
008408	M8 x 1	25	15	12	M8	4	75001	4
009411	M8 x 1	40	20	20	M8	3	75001	3
008416	M8 x 1	65	20	12	M8	1	75001	1
009508	M10 x 1	26	20	26	M10	8	75001	8
009509	M10	50	20	10	M10	2	65020/21	2

HEXAGON NUT

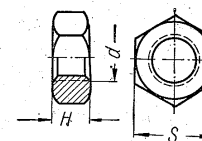

Fig. 62

Nut number	Main dimensions, mm			Q'ty per motorcycle	Group	Q'ty per group
	d x t	S	H			
001102	M5	8	4	15	7204	1
					72H09	4
					7211	2
					7215	3
					75017/18	2
001103	M6	10	5	18	65021	3
					75001	3
					7203	1
					72H09	3
					7211	1
					75017/18	2
					65020	4
65021	4					
250510	M8	14	6	2	65021	2
250511	M8 x 1	14	6	61	75001	15
					7204	3
					72H05	9
					5308	2
					72H09	12
					7211	3
					65020	4
					65020/21	8
					65021	5
					250513	M10 x 1
72H06	2					
5308	2					
72H09	4					
7211	2					
5313	1					
5314	1					
65020	5					
65020/21	3					
250515	M12 x 1.25	19	10	9		
250559	M14 x 1.5	22	11	2	65020	2
					65020	2

¹ One piece is a component of part 5309277.

HEXAGONAL PLAIN NUT

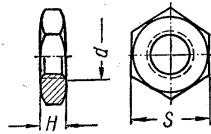

Fig. 63

Nut number	Main dimensions, mm			Q'ty per motorcycle	Group	Q'ty per group
	d × t	S	H			
250613	M10 × 1	17	6	4	7204 7211 75017/18 65020/21	1 1 1 1
250638	M18 × 1.5	27	9	2	65020	2

HEXAGONAL SLOTTED NUT

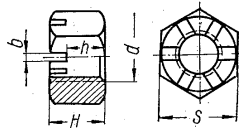

Fig. 64

Nut number	Main dimensions, mm					Q'ty per motorcycle	Group	Q'ty per group
	d × t	S	H	h	b			
250867	M8 × 1	14	9	5.5	2.5	1	72H05	1
250869	M12 × 1.25	19	15	10	3.5	4	65020	4
367202	M14 × 1.5	22	19	11	3.5	1	72H06	1
367201	M20 × 1.5	27	14	8	4.5	1	65020	1

WASHER

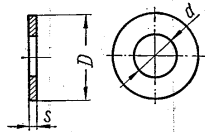

Fig. 65

Washer number	Main dimensions, mm			Q'ty per motorcycle	Group	Q'ty per group	Washer number	Main dimensions, mm			Q'ty per motorcycle	Group	Q'ty per group
	d	D	S					d	D	S			
1	2	3	4	5	6	7	1	2	3	4	5	6	7
252002	4.2	10	1	32	75001 65021	1 31	252003	5.5	12	1.2	5	7204 7215 65021	1 1 3

Continued

1	2	3	4	5	6	7	1	2	3	4	5	6	7
252004	6.5	14	1.5	36	75001 7203 7204 5308 72H09	9 1 11 12 3	010505	10.5	18	1.5	5	7211 65020 65020/21 65021	1 3 8 3
252005	8.5	18	1.5	36	75001 7204 72H05 72H09	10 2 6 3	252007	12.5	.26	2	5	5308 7210 72H09 65021	4 1 3 2

SPRING WASHER

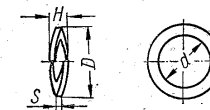

Fig. 66

Washer number	Main dimensions, mm			Q'ty per motorcycle	Group	Q'ty per group	Washer number	Main dimensions, mm			Q'ty per motorcycle	Group	Q'ty per group		
	d	D	S					d	D	S					
252153	5.4	8.6	1.2	12	75001 7215 75017/18 72H09	4 1 4 3	252154	6.5	10.5	1.2	37	75001 72H05 72H06 5308 72H09 7211 75017/18 65020 65021	20 1 1 1 3 1 2 4 4	7211 5313 5314 75017/18 65020 65020/21 65021	2 2 3 1 10 8 4
252154	6.5	10.5	1.2	37	75001 72H05 72H06 5308 72H09 7211 75017/18 65020 65021	20 1 1 1 3 1 2 4 4	252156	10.5	17.5	2	25	7204 72H06 72H09 7211 5313 5314 65020 65020/21	1 2 8 3 1 2 6 2		
252155	8.5	13.5	1.8	58	75001 7204 72H05 5308 72H09 7210	4 1 4 5 12 2	252157	12.5	20.5	2.5	7	72H09 65020	5 2		
							258158	15	24	2.5	2	65020	2		

SPACER

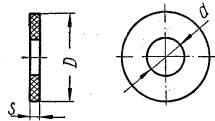

Fig. 67

Spacer number	Main dimensions, mm			Q'ty per motorcycle	Group	Q'ty per group
	d	D	S			
011407	14.2	20	1.5	6	75001	1
					7204	2
					72H05	2
					7210	1
01142	24.3	32	1.5	1	75001	1

CYLINDRICAL PIN



Fig. 69

Pin number	Main dimensions, mm		Number per motorcycle	Group	Number per group
	d	l			
258341	2	25	2	72H06	2
258612	4	12	2	75001	2
258626	5	15	1	75001	1
258640	6	18	2	7204	2
258710	3	15	1	65021	1

CIRCULAR KEY

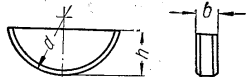

Fig. 68

Key number	Main dimensions, mm			Number per motorcycle	Group	Q'ty per group
	b	d	h			
014107	3	13	5	2	75001	2
014110	4	13	5	1	75001	1

COTTER WIRE

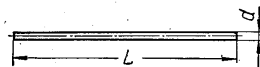

Fig. 70

Wire number	Main dimensions, mm		Q'ty per motorcycle	Group	Q'ty per group
	d	l			
258222	0.8	100	1	75001	1
258240	0.8	600	1	75001	1

SPLIT COTTER



Fig. 71

Cotter number	Main dimensions, mm				Q'ty per motorcycle	Group	Q'ty per group
	d	l	h	a			
1	2	3	4	5	6	7	8
258002	1.3	15	3.5	2	1	5308	1
258013	1.8	15	5	2	3	75001	1
						7203	1
						7211	1
258014	1.8	20	5	2	3	72H05	1
						72H09	2

Continued

1	2	3	4	5	6	7	8
258026	2.2	25	6	3	6	75001	1
						7204	1
						72H06	1
						72H09	2
258041	2.7	30	7.5	3	5	7204	1
						65020	4
258053	3.6	35	9	5	1	7204	1
258055	3.6	35	9	5	1	65020	1
258071	4.6	45	11.5	5	4	65020	4

PIN

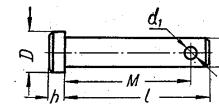

Fig. 72

Stud number	Main dimensions, mm						Q'ty per motorcycle	Group	Q'ty per group
	d	l	D	h	d ₁	M			
260041	4	42	12	2.5	3	38	2	72H09	2

CUP-HEADED SCREW NAIL

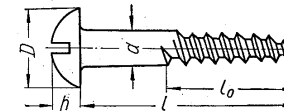

Fig. 73.

Screw nail number	Main dimensions, mm					Q'ty per motorcycle	Group	Q'ty per group
	d	l	l ₀	D	h			
247522	3	18	8	5.5	2.3	16	65021	16
247547	4	22	13	7.5	3	18	65021	18

COUNTERSUNK-HEADED SCREW NAIL

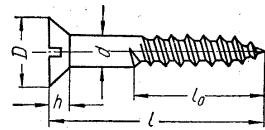

Fig. 74

Screw nail number	Main dimensions, mm					Q'ty per motorcycle	Group	Q'ty per group
	d	l	l ₀	D	h			
248037	5	30	16.5	10	2.5	35	65021	35

CUP RIVET

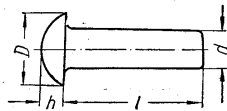

Fig. 75

Rivet number	Main dimensions, mm				Q'ty per motorcycle	Group	Q'ty per group
	d	l	D	h			
252539	3	6	5.5	2.3	2	7215	2
252548	3	24	5.5	2.3	2	65021	2
252549	3	26	5.5	2.3	2	65021	2
252594	5	16	9.5	3.6	7	65020	7

COUNTERSUNK RIVET

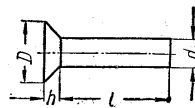

Fig. 76

Rivet number	Main dimensions, mm				Q'ty per motorcycle	Group	Q'ty per group
	d	l	D	h			
253553	4	10	8	2	16	7203	16

CUP HOLLOW RIVET

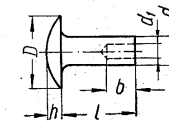

Fig. 77

Rivet number	Main dimensions, mm						Q'ty per motorcycle	Group	Q'ty per group
	d	l	D	h	d ₁	b			
255038	3.5	7	7	1.2	2.4	4	25	65021	25

WIRE NAIL

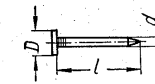

Fig. 78

Nail number	Main dimensions, mm			Q'ty per motorcycle	Group	Q'ty per group
	d	l	D			
261008	1	15	2	8	65021	8
261853	1.6	12	4.4	400	65021	400
261855	2	16	5.2	2	65021	2

LUBRICATOR

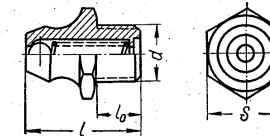

Fig. 79

Lubricator number	Main dimensions, mm				Q'ty per motorcycle	Group	Q'ty per group
	d	l	l ₀	S			
264072	M6 × 1 conical	13	5	8	13	7204 72H05 72H06 72H09 7211	1 2 6 3 1

SUPPLEMENTS

Supplement 1

COLOUR INDICES OF CRANK UNIT PARTS ACCORDING TO DIMENSIONS

Part 7201203 — *crank pin*. Numbers 316, 318, 320, 322 and 324, found on the crankpin end face, indicate parts weight in grams.

The colour indices correspond to the following dimensions:

Colour index	Crank pin diameter, mm
Red	36.000 to 35.996
White	35.996 to 35.992
Green	35.992 to 35.988
Black	35.988 to 35.984

Part 7201209 — *roller*.

The groups correspond to the following dimensions:

Group number	Roller diameter, mm
1	7.004 to 7.002
2	7.002 to 7.000
3	7.000 to 6.998
4	6.998 to 6.996
5	6.996 to 6.994
6	6.994 to 6.992

Part 7201236-A — *connecting rod, assembled*. Numbers 198, 200, 202 and 204, found on the outer surface of the connecting rod lower head, indicate the weight of the latter in grams. Colour indices of the connecting rod lower heads correspond to the following dimensions:

Colour index	Lower head opening diameter, mm
Red	50.012 to 50.009
White	50.009 to 50.006
Green	50.006 to 50.003
Black	50.003 to 50.000

Colour indices of the connecting rod upper heads correspond to the following dimensions:

Colour index	Upper head opening diameter, mm
Red	21.005 to 21.002
White	21.002 to 20.999
Green	20.999 to 20.996
Black	20.996 to 20.993

Part 72H01237 — *piston*.

Colour indices of the main pin holes correspond to the following dimensions:

Colour index	Pin hole diameter, mm
Red	20.991 to 20.988
White	20.988 to 20.985
Green	20.985 to 20.982
Black	20.982 to 20.979

The indices, found on the piston heads, correspond to the following dimensions:

Group index	Skirt diameter (measured in the plane normal to piston pin axis), mm
77.95	77.950 to 77.940
77.94	77.940 to 77.930
77.93	77.930 to 77.920

Part 7201238 — *piston pin*.

Colour indices of the pin diameters correspond to the following dimensions:

Colour index	Piston pin diameter, mm
Red	20.998 to 20.995
White	20.995 to 20.992
Green	20.992 to 20.989
Black	20.989 to 20.986

Part 7201301 — right-hand cylinder
 and part 7201302 — left-hand cylinder.
 The indices, found on the cylinders above the lugs
 for valve springs, correspond to the following dimensions:

Group index	Cylinder diameter, mm
03	78.030 to 78.020
02	78.020 to 78.010
01	78.01 to 78.000

Supplement 2

Summary conversion table of sidecar chassis
 catalogue numbers
 (group 65020)

Part number	
M-72	K-650
72-20018-B2	650202-10
72-20050	650202-4
72-20051	650202-5
72-20054-A	650202-6
72-20055-A	650202-7
72-20304	65020231

Continued

Part number	
M-72	K-650
72-20305-B	65020233
72-20320	65020213
72-20321-B	65020214
72-20325	65020215
72-20605-B	65020303
И20Б-9002064	65020201

Supplement 3

Summary conversion table of sidecar body
 catalogue numbers
 (group 65021)

Part number	
M-72	K-650
72-21050	650212-2
72-21075	650212-3
72-21078-A	650215
72-21104	65021006
72-21341-B	65021233

CONTENTS

	Page
Introduction	5
Index to Part I	9
Index to Part II	10
Index to Part III	10
Part I. Assemblies, units and parts of the K-750 motorcycle	13
Part II. Fittings supplied by other manufactures	63
Part III. Fastenings	72
Supplement I. Colour indices of crank unit parts accord- ing to dimensions	85
Supplement II. Summary conversion table of sidecar chassis catalogue numbers (group 65020)	86
Supplement III. Summary conversion table of sidecar body catalogue numbers (group 65021)	86

Vneshtorgizdat. Order № 3142 y.

Resp.: *Shapovalov I. F., Lototskaya S. N., Gorkavenko L. I.*